



ANSI / ISEA Z87.1-2020

---

# American National Standard for Occupational and Educational Personal Eye and Face Protection Devices

**ANSI/ISEA Z87.1-2020**  
Revision of  
ANSI/ISEA Z87.1-2015

**American National Standard  
Occupational and Educational  
Personal Eye and Face  
Protection Devices**

Secretariat  
**International Safety Equipment Association**

Approved March 11, 2020  
**American National Standards Institute, Inc.**

## **American National Standard**

An American National Standard implies a consensus of those substantially concerned with its scope and provisions. An American National Standard is intended as a guide to aid the manufacturer, the consumer, and the general public. The existence of an American National Standard does not in any respect preclude anyone, whether they have approved the standard or not, from manufacturing, marketing, purchasing, or using products, processes, or procedures not conforming to the standard. American National Standards are subject to periodic review and users are cautioned to obtain the latest editions.

The American National Standards Institute does not develop standards and will in no circumstances give an interpretation of any American National Standard. Moreover, no persons shall have the right or authority to issue an interpretation of an American National Standard in the name of the American National Standards Institute.

**CAUTION NOTICE:** This American National Standard may be revised or withdrawn at any time. The procedures of the American National Standards Institute require that action be taken to reaffirm, revise, or withdraw this standard no later than five years from the date of publication. Purchasers of American National Standards may receive current information on all standards by calling or writing the American National Standards Institute.

Published by

**International Safety Equipment Association  
1901 North Moore Street, Suite 808, Arlington, Virginia 22209 USA**

Copyright 2020 by ISEA

All rights reserved.

No part of this publication (with the exception of Annex J, Selection Chart) may be reproduced in any form, in an electronic retrieval system or otherwise, without the prior written permission of the publisher.

Printed in the United States of America

## Foreword (This Foreword is not a part of ANSI/ISEA Z87.1-2020)

ANSI/ISEA Z87.1-2020 represents the sixth revision of the voluntary industry consensus standard for eye and face protection, which is also codified in regulatory text by the U.S. Occupational Safety and Health Administration obliging employers to provide employees with appropriate safety eyewear and face protection that conforms to the industry standard.

The document continues to focus on product performance and harmonization with global standards in an effort to allow new and innovative designs responsive to workplace hazards and end-user needs. To this end, this current version includes criteria and requisite markings for protectors offering relaxed optics, as an option to the long-standing requirements. This in response to the recognition that certain job tasks and applications, such as those performed by first-responder, firefighting or military personnel, may not need require the stringent optical criteria historically imposed. It is cautioned that protectors with relaxed optics may not be appropriate for industrial applications such machinery operation, precision work, or in laboratory environments, and as such, a proper hazard assessment should be conducted.

Additionally, the 2020 version includes testing, performance and marking criteria for lenses with anti-fog properties. While this lens-only assessment is a departure from a final configuration approach generally applied throughout the standard, it is recognized that fogging can impede a wearer's ability to perform work safely. Such requirements are consistent with criteria in similar global standards and have been incorporated for the benefit of the wearer

Other key updates address the emergence of innovating product designs which past editions did not contemplate. These are seen by changings transmittance allowances and expanded welding filter shades. Additional clarifications have been made throughout to provide consistency in testing execution such as when applying dark-state tolerances for automatic darkening welding filters or determining the minimum coverage area with respect to the specified headform.

Suggestions for improvement of this standard are welcome. They should be sent to the International Safety Equipment Association, [isea@safetysafetyequipment.org](mailto:isea@safetysafetyequipment.org).

This standard was processed and approved for submittal to ANSI by the Accredited Standards Committee on Safety Standards for Eye Protection, Z87. Committee approval of the standard does not necessarily imply that all committee members voted for its approval. At the time it approved this standard, the Z87 Committee had the following members:

J.P Sankpill, Chairman  
Jack B. Hirschmann, Jr., Vice-Chairman

### **Organization Represented**

American Optometric Association  
  
American Society of Safety Professionals  
American Welding Society  
Essilor USA  
ICS Laboratories, Inc.  
  
Individual Member  
Individual Member

### **Name of Representative**

Aaron Zimmerman, O.D., MS  
Gregory Good, O.D., Ph.D.  
Jack B. Hirschmann, Jr.  
David Sliney  
J.P. Sankpill  
Emmanuel Alabi, O.D., Ph.D.  
Keith Whitten  
Michael Kertis  
Jack Laptad

International Safety Equipment Association

Jones and Company  
Kimberly-Clark Professional  
The Laboratory Safety Institute

3M Company  
National Association of Optometrists  
and Opticians  
National Institute for Occupational  
Safety and Health (NIOSH)  
Optical Laboratories Association

Opticians Association of America  
Power Tools Institute

Safety Equipment Institute

UL LLC

U.S. Department of the Air Force

U.S. Department of the Army

U.S. Department of the Navy

The Vision Council

Walter Surface Technologies  
Younger Optics  
ANSI Z80 Committee Ophthalmic Lenses

Individual Expert (non-voting)

Jud Crosby  
Cristine Z. Fargo, CAE  
Bruce Hey  
Joann M. Kline, JD  
James Kaufmann, Ph.D.  
Dr. Rajeev Santhappa  
Keith A. Fecteau  
Rob Fontaine  
Jeremy Swan  
James R. Harris, Ph.D.  
Jonathan Szalajda  
Neil Torgersen  
Michael Vitale  
Tom Hicks  
Al Pierga  
Brett Cohen  
Anna Seiple  
Dean Moran  
David Salter  
Robin Tutor  
LtCol. Luanne Danes  
Robert N. Kang  
Major Jin B. Ha  
LtCol James Truong  
LCDR Hong Gao  
Dr. Michael Pattison  
Michael Vitale  
Tom Sadler  
Jennifer Panzek  
Koby Curtis  
Dick Whitney  
Neil Torgersen  
Dale B. Pfriem

# Table of Contents

| TOPIC  | PAGE |
|--|------|
| Foreword   |      |
| 1 Preface .....  | 1    |
| 2 Scope, Purpose, Application, and Interpretations .....         | 1    |
| 2.1 Scope.....   | 1    |
| 2.2 Purpose.....   | 1    |
| 2.3 Application.....   | 1    |
| 2.4 Interpretations .....  | 2    |
| 3 Definitions .....  | 2    |
| 4 Normative References.....                                      | 6    |
| 5 Fundamental Design Requirements for All Protectors .....       | 6    |
| 5.1 Optical Requirements .....                                   | 6    |
| 5.2 Physical Requirements.....                                   | 7    |
| 5.3 Markings .....   | 8    |
| 5.4 Other Requirements .....                                     | 10   |
| 5.5 Replaceable Lenses.....                                      | 10   |
| 5.6 Aftermarket Components and Accessories .....                 | 11   |
| 6 Optional Design Characteristics .....                          | 11   |
| 6.1 Relaxed Optics Level.....                                    | 11   |
| 6.2 Anti-Fog Properties.....                                     | 11   |
| 7 Optional Hazard-Specific Requirements .....                    | 11   |
| 7.1 Impact-Protector Requirements .....                          | 11   |
| 7.2 Optical Radiation Protector Requirements .....               | 14   |
| 7.3 Droplet and Splash Protector Requirements .....              | 18   |
| 7.4 Dust Protector Requirements .....                            | 18   |
| 7.5 Fine Dust Protector Requirements .....                       | 18   |
| 8 RESERVED FOR FUTURE USE .....                                  | 19   |
| 9 Test Methods.....  | 19   |
| 9.1 Optical Quality Test.....                                    | 19   |
| 9.2 Transmittance Test.....                                      | 19   |
| 9.3 Haze Test .....  | 19   |
| 9.4 Refractive Power, Astigmatism and Resolving Power Tests..... | 19   |
| 9.5 Prismatic Power Test .....                                   | 20   |
| 9.6 Drop Ball Test.....  | 21   |
| 9.7 Ignition Test.....   | 21   |
| 9.8 Corrosion Resistance Test.....                               | 21   |
| 9.9 Light Tightness Test .....                                   | 22   |
| 9.10 Lateral Protection Test.....                                | 22   |

|          |  |    |
|----------|--|----|
| 9.11     | High Mass Impact Test .....  | 22 |
| 9.12     | High Velocity Impact Test.....   | 23 |
| 9.13     | Penetration Test .....   | 24 |
| 9.14     | Prescription Lens Material Qualification Test .....  | 25 |
| 9.15     | Switching Index Test .....   | 25 |
| 9.16     | Angular Dependence of Luminous Transmittance Test for Automatic Welding<br>Filter Devices.....           | 26 |
| 9.17     | Droplet and Splash Test.....   | 27 |
| 9.18     | Dust Test.....   | 28 |
| 9.19     | Fine Dust Particle Test.....   | 29 |
| 9.20     | Anti-Fog Lens Test .....   | 30 |
| 10       | Instructions, Use and Maintenance .....  | 31 |
| 10.1     | General .....  | 31 |
| 10.2     | Instructions.....  | 31 |
| 10.3     | Inspections .....  | 31 |
| 10.4     | Maintenance and Care .....   | 31 |
| 10.5     | Training.....  | 31 |
| Annexes  |  |    |
| Annex A  | Samples for Testing (normative).....   | 32 |
| Annex B  | Reference Headforms (normative) .....  | 33 |
| Annex C  | Spectral Factor Tables (normative) .....   | 35 |
| Annex D  | Lateral (Side) Coverage Illustration (Medium Headform) (informative).....                                | 39 |
| Annex E  | Test Apparatus (informative) .....   | 40 |
| Annex F  | Calibration of Test Telescope (informative) .....  | 45 |
| Annex G  | Illustrations to Aid in Refractive Power, Astigmatism and Resolving<br>Power Testing (informative) ..... | 46 |
| Annex H  | Sources for Test Apparatus (informative) .....   | 47 |
| Annex I  | Resource Publications (informative).....   | 48 |
| Annex J  | Eye and Face Selection Guide (informative).....  | 49 |
| Annex K  | Hazard Assessment and Protector Selection (informative) .....  | 54 |
| Annex L  | Examples of Protector Markings (informative).....  | 59 |
| Tables   |  |    |
| Table 1  | Tolerance on Refractive Power, Astigmatism and Resolving Power –<br>Standard Optics .....                | 7  |
| Table 2  | Tolerance on Prism and Prism Imbalance .....   | 7  |
| Table 3  | Marking Requirements .....   | 9  |
| Table 4  | Minimum Thickness Requirements for Prescription Lenses.....  | 10 |
| Table 5  | Tolerance on Refractive Power, Astigmatism and Resolving Power -<br>Relaxed Optics .....                 | 12 |
| Table 6  | High Velocity Impact Testing .....   | 13 |
| Table 7  | Transmittance Requirements for Welding Filter Lenses.....  | 16 |
| Table 8  | Transmittance Requirements for Ultraviolet Filter Lenses .....   | 16 |
| Table 9  | Transmittance Requirements for Infrared Filter Lenses.....   | 17 |
| Table 10 | Transmittance Requirements for Visible Light Filter Lenses .....   | 17 |
| Table 11 | Transmittance Requirements for Special Purpose Filter Lenses .....                                       | 17 |
| Table 12 | Switching Index Requirements for Automatic Darkening<br>Welding Filter Lenses .....                      | 18 |
| Table 13 | Angular Dependence of Luminous Transmittance.....  | 18 |

# American National Standard for Occupational and Educational Personal Eye and Face Protection Devices

## 1. Preface

This standard for personal eye and face protectors is, as far as possible, designed to be performance oriented.

Every effort should be made to eliminate eye and face hazards in occupational and educational settings. Protectors do not provide unlimited protection. In the occupational and educational environment, protectors are not substitutes for machine guards and other engineering controls. Protectors alone should not be relied on to provide complete protection against hazards, but should be used in conjunction with machine guards, engineering controls, and sound safety practices.

In 1992, the U.S. Occupational Safety and Health Administration began regulating occupational exposure to bloodborne pathogens and, as a result, employers are required to provide personal protective equipment (PPE) including eye and face protection for employees exposed to these hazards. At the time of the publication of this standard, no standards existed for eye and face protection intended to provide protection from bloodborne pathogens. Nevertheless, many employers have elected to provide their employees with PPE conforming to the requirements of ANSI/ISEA Z87.1. These products may or may not provide adequate protection against bloodborne pathogens. Extreme caution must be exercised in the selection and use of personal protective equipment in applications for which no performance requirements or standardized testing exist.

## 2. Scope, Purpose, Application, and Interpretations

### 2.1 Scope

This standard sets forth criteria related to the requirements, testing, permanent marking, selection, care, and use of protectors to minimize the occurrence and severity or prevention of injuries

from such hazards as impact, non-ionizing radiation and liquid splash exposures in occupational and educational environments including, but not limited to, machinery operations, material welding and cutting, chemical handling, and assembly operations. Certain hazardous exposures are not covered in this standard. These include, but are not limited to: bloodborne pathogens, X-rays, high-energy particulate radiation, microwaves, radio-frequency radiation, lasers, masers, and sports and recreation.

### 2.2 Purpose

This standard provides minimum requirements for protectors including selection, use, and maintenance of these protectors as devices to minimize or prevent eye and face injuries.

### 2.3 Application

**2.3.1** The requirements of this standard apply to protectors when first placed in service.

**2.3.2** Protectors bearing the permanent marking Z87 shall meet all applicable requirements of this standard in its entirety. All components of eye and face protectors shall comply with the requirements of this standard. Accessories installed by the manufacturer shall not cause the protector to fail the requirements of this standard. Manufacturers of components, aftermarket components, accessories and complete protectors shall ensure that all required tests have been performed to demonstrate conformance.

**2.3.3** Compliance with this standard cannot always be assured when components are replaced or accessories are added. End users should exercise extreme care in the selection and installation of components to ensure compliance with this standard.

**2.3.4** Non-compliant components shall not be used with ANSI/ISEA Z87.1-compliant components.



**2.3.5** The protector manufacturer shall provide test results to the purchaser upon request.

**2.3.6** Eye and face protectors complying with the requirements of this standard shall not preclude the devices from complying with other relevant standards, as applicable.

## 2.4 Interpretations

Requests for interpretations of this standard shall be in writing and addressed to the secretariat ([isea@safetyequipment.org](mailto:isea@safetyequipment.org)) of this accredited standard committee.

## 3. Definitions

For purposes of this standard, the following definitions shall apply:

**accessory.** An item that is added to a complete device that may or may not affect the performance of that complete device.

**aftermarket component.** A component that may or may not be manufactured by the complete device manufacturer and is not supplied with the original complete device.

**astigmatism.** A condition in a lens of a protector in which there is a difference in refractive power in one meridian from that in another meridian.

**automatic darkening welding filter lens.** A filter lens that automatically switches from a light state to a dark state in response to a change of light intensity.

**bluelight transmittance  $\tau_B$ .** Transmittance of optical radiation weighted by its ability to cause photochemical damage to the retina is defined as:

$$\tau_B = \frac{\int_{400}^{700} \tau(\lambda) B(\lambda) d\lambda}{\int_{400}^{700} B(\lambda) d\lambda}$$

where  $B(\lambda)$  is the BlueLight Hazard Function defined in Table C4 of Annex C.

**chin protector.** That portion of a device that offers protection to a wearer's lower face, chin and neck.

**claim.** A mark, made according to Section 5.3, indicating that the device meets the performance requirement of this standard reflected by that mark.

**complete device.** A product with all its components in their configuration of intended use.

**component.** A functional part of a complete device that is addressed by the performance requirements of this standard (e.g. lens, frame, crown).

**cover lens.** An expendable lens used to protect another lens from surface damage and that is not intended to contribute to user protection. It is not a safety plate.

**crown.** A component that offers protection to a wearer's forehead.

**dark state.** The lowest operating luminous transmittance of an automatic darkening filter lens.

**diopter (D).** A unit of measurement (plus or minus) used to express the power of a lens. It is expressed as the reciprocal of the focusing distance given in meters. The diopter is also used to express the curvature of surfacing tools and the refracting power of curved surfaces.

### effective far-ultraviolet average transmittance

**$\bar{\tau}$  (EFUV).** Transmittance of optical radiation with wavelengths from 200 to 315 nanometers weighted by its ability to damage the cornea. When  $\tau(\lambda)$  is defined as the spectral transmittance of the filter at wavelength,  $\bar{\tau}$  (EFUV) is defined as:

$$\bar{\tau}(EFUV) = \frac{\int_{200}^{315} \tau(\lambda) S(\lambda) d\lambda}{\int_{200}^{315} S(\lambda) d\lambda}$$

where  $S(\lambda)$  is the Relative Spectral Effectiveness given in Table C1 of Annex C.

**faceshield.** A protector intended to shield the wearer's face, or portions thereof, from certain hazards, as indicated by the faceshield's markings.

**filter lens.** A lens that attenuates specific wavelengths of ultraviolet, visible, and/or infrared radiation.

**fracture.** A lens, frame, or lens housing or carrier cracks through its entire thickness to the inner surface into two or more separate pieces.

**frame.** A structure which holds the lens or lenses.

**front.** That part of a spectacle frame that is intended to contain the lens or lenses.

**full facepiece respirator.** A tight-fitting respirator that covers the nose, mouth and eyes from approximately the hairline to below the chin.

**goggle.** A protector intended to tightly fit the face surrounding the eyes in order to shield the eyes from certain hazards, as indicated by the goggle's markings.

**handshield.** A hand-held welding helmet. See "welding helmet."

**haze.** The percent of incident light that is not transmitted in a straight line through the lens but forward scattered, greater than  $2.5^\circ$  diverging.

**headform.** Apparatus constructed in accordance with specifications outlined in EN168:2001, Section 17 utilized in the testing of protective devices as specified in Section 9, Test Methods. (Refer to Annex B)

**infrared average transmittance.** Transmittance of optical radiation with wavelengths from 780 to 2000 nanometers weighted by its ability to damage the cornea. When  $\tau(\lambda)$  is defined as the spectral transmittance of the filter at wavelength,

$\bar{\tau}$  (IR) is defined as:

$$\bar{\tau}(IR) = \frac{\int_{780}^{2000} \tau(\lambda) S_A(\lambda) d\lambda}{\int_{780}^{2000} S_A(\lambda) d\lambda}$$

where, in the infrared, the relative spectral emittance  $S_A(\lambda)$  of Illuminant A is that of a full ("Black-body") radiator at temperature  $2856^\circ\text{K}$  ( $4681^\circ\text{F}$ ) and is given in Table C3 of Annex C.

**infrared radiation (IR).** As related to this standard, electromagnetic energy with wavelengths from 780 to 2000 nanometers.

**inner surface.** The inward facing portions of any component of a complete device which have a direct line to the eye or lateral coverage area per Section 7.1.3.

**lens.** A component through which the wearer sees.

**lens housing or carrier.** A component that holds a lens or lenses.

**lift-front.** A moveable lens housing that can be positioned either inside or outside of the wearer's line of sight.

**light.** Optical radiation weighted by its ability to cause visual sensations.

**light state.** The highest luminous transmittance of an automatic darkening welding filter lens, when not in a dark state.

**loose-fitting respirator.** A respiratory inlet covering that is designed to form a partial seal with the face, or that completely covers the head and neck, and may cover portions of the shoulder.

**luminous transmittance ( $\tau_l$ ).** The fraction of light (380-780 nm) passing through a medium, is defined in this standard with respect to the light source CIE Illuminant A and the CIE 1931 Standard Colorimetric Observer, and is expressed as:

$$\tau_L = \frac{\int_{380}^{780} \tau(\lambda) \bar{y}(\lambda) S_A(\lambda) d\lambda}{\int_{380}^{780} \bar{y}(\lambda) S_A(\lambda) d\lambda}$$

where  $\bar{y}(\lambda)$  is the relative luminous efficiency function and  $S_A(\lambda)$  is the relative spectral emittance of Illuminant A as defined by the CIE. These functions are given in Table C2 of Annex C.

**magnifier.** A mass-produced lens (non-prescription) that incorporates plus refractive power throughout the entirety of the lens. This includes spectacle lenses but does not include magnifiers inserted into welding devices, which are considered to be accessories.

**manufacturer.** The business entity that marks or directs the permanent marking of the components or complete devices as compliant with this standard, and sells them as compliant.

**near-ultraviolet average transmittance.** Transmittance of optical radiation with wavelengths from 315 to 380 nanometers. When  $\tau(\lambda)$  is defined as the spectral transmittance of the filter at wavelength,  $\bar{\tau}$  (NUV) is defined as:

$$(NUV) = \frac{\int_{315}^{380} \tau(\lambda) d\lambda}{\int_{315}^{380} d\lambda}$$

**non-removable lens.** A lens and holder that are homogeneous and continuous or a lens that cannot be removed from the frame/front without damage to the device.

**optical radiation.** As related to this standard, that portion of the electromagnetic spectrum ranging in wavelength from 200 nm to 2000 nm.

**permanent mark/markings.** A mark that cannot be removed without evidence of removal.

**photochromic lens.** A lens which darkens when exposed to, and fades when removed from, ultraviolet radiation and/or sunlight.

**plano lens.** A lens that does not incorporate a

corrective prescription; this lens is not necessarily flat.

**power.** See "refractive power", "resolving power", and "prismatic power".

**prescription lens (Rx).** A lens manufactured to the wearer's individual corrective prescription.

**prescription lens carrier.** A lens housing for mounting prescription lenses behind a protective lens.

**prismatic power, "prism".** A measure of the angular deviation expressed in prism diopters ( $\Delta$ ) of a light ray after passing along the viewing path through a lens. One prism diopter equals a deviation of 1 cm per meter of path length.

**protector.** A complete device meeting, at a minimum, the requirements of Section 5 of this standard.

**reader.** A mass produced non-prescriptive spectacle that incorporates plus refractive power in a portion of the lens.

**refractive power, "power".** A measure of the ability of a lens to focus light rays, expressed in diopters (D).

**removable lenses.** Lenses fabricated to fit a single spectacle frame.

**replaceable lenses.** Lenses intended by the manufacturer to be interchangeable by the user.

**representative test lenses.** Lenses produced of the same material(s), coatings, minimum thicknesses, lens surfacing and framing processes as used by the manufacturer.

**resolving power.** The measure of the ability of a lens to form separate images of two objects close together.

**retained.** In this standard, the use of the word "retained" means that the lens is not separated or visibly displaced from the frame by more than 25% of its intended mounting structure or support.

**safety plate.** The lens portion of the device that provides impact protection in the lens region of the protector. This is not a cover lens.

**scale.** A designator in which the first character indicates the type of radiation protector and the second character is a number which increases with more attenuation. The radiation protector characters are U for an ultraviolet radiation attenuator, R for infrared radiation attenuator and L for visible radiation attenuator.

**screen.** A mesh or gauze material made of any suitable substance (e.g. metal wire, plastic filament or fiber).

**shade, S.** Related to luminous transmittance,  $\tau_L$  (expressed as a fraction, not as a percent) by the equation:

$$S = \frac{7}{3} \log_{10} \frac{1}{\tau_L} + 1$$

**shall.** In this standard, the use of the word "shall" indicates a mandatory requirement.

**shell.** A component of a welding helmet or hand-shield that covers the wearer's face, ears and neck.

**should.** In this standard, the use of the word "should" indicates a recommendation.

**sideshield.** A component of a spectacle that provides lateral protection.

**special purpose filters/lenses.** Filters and lenses which meet the requirements of Table 11, but may or may not meet the requirements of Table 7, 8, 9 or 10. They are designed for specific applications.

**spectacle.** A protector intended to shield the wearer's eyes from certain hazards, as indicated by the spectacle's marking.

**switching index.** The response time of an automatic darkening welding filter lens is defined as:

*Switching Index*

$$= \frac{1}{\tau_1} \int_{t=0}^{t(\tau=3\tau_2)} \tau(t) dt$$

where:  $t = 0$  is the time at which the arc ignites,  $\tau_1$  is the luminous transmittance at the designated light state,  $\tau_2$  is the luminous transmittance at the designated dark state,  $t[\tau = 3\tau_2]$  is the time at which the luminous transmittance falls to three times the luminous transmittance in the dark state.

**NOTE:** During short term exposure to light, the discomfort of bright light is approximately proportional to the product of the illuminance at the eye and time. The time dependence of the darkening process can differ for different designs of filters where the luminous transmittance varies with time. It is therefore appropriate to define the response time of an automatic darkening filter lens as an integral of the luminous transmittance over time and not merely by the initial and final luminous transmittance.

**temple.** A spectacle component that extends partially around the head or behind the ear of the wearer.

**tinted lens.** A lens with color such as amber, smoke, or cobalt which may not meet the requirements of Table 7, 8, 9 or 10.

**type tests.** One or more tests performed on an item to approve a material, construction, model or design to determine if it is capable of meeting the requirements of a product standard.

**ultraviolet radiation (UV).** Electromagnetic energy with wavelengths from 200 to 380 nanometers.

**variable tint lens.** A lens which darkens or fades by some mechanism, excluding automatic darkening welding filters. These are typically photochromic lenses and may or may not meet the requirements of Table 7, 8, 9 or 10.

**visible light filter.** A filter lens intended for the attenuation of visible light. This may be a sun-glass or special purpose lens.

**welding goggle.** A goggle intended to provide optical radiation protection for limited welding applications.

**welding faceshield.** A faceshield intended to provide optical radiation protection for specific welding applications.

**welding filter lens.** A lens specified for use for welding or brazing.

**welding helmet.** A device intended to provide protection specifically to the eyes and face against welding-related optical radiation and weld spatter.

**welding respirator.** A respirator intended to provide optical radiation protection for welding operations.

**window.** The lens portion of a faceshield (see “lens”).

#### 4. Normative References

The following documents contain provisions, which, through reference in this text, constitute mandatory provisions of this standard. Other resource materials, which do not contain mandatory provisions, are listed in Annex I.

American Conference of Governmental Industrial Hygienists - *Threshold Limit Values for Chemical Substances and Physical Agents & Biological Exposure Indices for 2017*

ANSI Z80.1-2015, *American National Standard for Ophthalmics - Prescription Ophthalmic Lenses – Recommendations*

ANSI Z80.3-2018, *American National Standard for Ophthalmics - Nonprescription Sunglasses and Fashion Eyewear – Requirements*

ANSI/ISO 7998 / 8624 / 12870 - *Optics Set, Ophthalmic Optics - Spectacle Frames - Lists of Equivalent Terms And Vocabulary, Measuring System And Terminology, And Requirements And Test Methods*

ASTM D1003-13, *Standard Test Method for Haze and Luminous Transmittance of Transparent Plastics*

EN 168:2001, *European Standard – Personal eye protection – Non-optical test methods*

#### 5. Fundamental Design Requirements for All Protectors

All protectors shall satisfy all applicable requirements of Section 5. Unless otherwise stated, all values for measurements are to be considered as nominal.

##### 5.1 Optical Requirements

###### 5.1.1 Optical Quality

When tested in accordance with Section 9.1, protector lenses shall be free of striae, bubbles, waves and other visible defects which would impair the wearer’s vision.

###### 5.1.2 Luminous Transmittance

When tested in accordance with Section 9.2, clear lenses shall have a luminous transmittance of not less than 85%.

###### 5.1.3 Haze – Clear Lenses Only

When tested in accordance with Section 9.3, clear plano lenses shall not exhibit more than 3% haze.

###### 5.1.4 Refractive Power, Astigmatism, Resolving Power, Prism and Prism Imbalance for Plano Protectors

When tested in accordance with Section 9.4, the tolerance on refractive power, astigmatism and resolving power shall be as indicated in Table 1. When tested in accordance with Section 9.5, the tolerance on prism and prism imbalance shall be as indicated in Table 2. Filter lenses of shade 9 or higher are exempt from this section.

| <b>Table 1. Tolerance on Refractive Power, Astigmatism and Resolving Power – Standard Optics</b> |                         |                    |                        |
|--|-------------------------|--------------------|------------------------|
| <b>Protector</b>   | <b>Refractive Power</b> | <b>Astigmatism</b> | <b>Resolving Power</b> |
| Spectacle, Reader  | $\pm 0.06$ D            | $\leq 0.06$ D      | Pattern 20             |
| Goggle, Full-facepiece respirator  | $\pm 0.06$ D            | $\leq 0.06$ D      | Pattern 20             |
| Faceshield windows, Loose-fitting respirator   | No requirement          | No requirement     | Pattern 20             |
| Welding helmet lenses  | $\pm 0.06$ D            | $\leq 0.06$ D      | Pattern 20             |

| <b>Table 2. Tolerance on Prism and Prism Imbalance</b> |                      |                           |                          |                           |
|--|----------------------|---------------------------|--------------------------|---------------------------|
| <b>Protector</b>                                       | <b>Prism</b>         | <b>Vertical Imbalance</b> | <b>Base In Imbalance</b> | <b>Base Out Imbalance</b> |
| Spectacle, Reader                                      | $\leq 0.50$ $\Delta$ | $\leq 0.25$ $\Delta$      | $\leq 0.25$ $\Delta$     | $\leq 0.50$ $\Delta$      |
| Goggle, Full-facepiece respirator                      | $\leq 0.25$ $\Delta$ | $\leq 0.125$ $\Delta$     | $\leq 0.125$ $\Delta$    | $\leq 0.50$ $\Delta$      |
| Faceshields, Loose-fitting respirator                  | $\leq 0.37$ $\Delta$ | $\leq 0.37$ $\Delta$      | $\leq 0.125$ $\Delta$    | $\leq 0.75$ $\Delta$      |
| Welding helmet lenses                                  | $\leq 0.50$ $\Delta$ | $\leq 0.25$ $\Delta$      | $\leq 0.25$ $\Delta$     | $\leq 0.75$ $\Delta$      |

### 5.1.5 Refractive Power, Astigmatism, Prism and Prism Imbalance for Prescription Protectors and Magnifiers

For prescription protectors and magnifiers, the tolerance on refractive power, astigmatism, prism and prism imbalance shall be those contained in ANSI Z80.1-2015.

NOTE: There is no resolving power requirement for prescription lenses and magnifiers.

## 5.2 Physical Requirements

Protectors shall be free from projections, sharp edges or other defects which are likely to cause discomfort or injury during use.

### 5.2.1 Drop Ball Impact Resistance

When tested in accordance with Section 9.6, the protector shall fail if any of the following occur

when impacted by a 25.4 mm (1 in.) diameter steel ball when dropped from a height of 127 cm (50 in.):

- lens (lens only) fractures
- piece fully detached from the inner surface
- projectile penetrates the inner surface
- lens not retained

Glass welding filter lenses shall be tested and used in conjunction with a safety plate in order to comply with the drop ball impact performance criteria.

Protectors first tested to and meeting the requirements of Section 7.1.4 are exempt from drop ball impact testing.

### 5.2.2 Ignition

When tested in accordance with Section 9.7, protectors shall not ignite or continue to glow once the rod is removed. Each externally exposed material (exclusive of textiles or elastic bands) shall be tested.

### 5.2.3 Corrosion Resistance of Metal Components

When tested in accordance with Section 9.8, metal components used in protectors shall be corrosion resistant to the degree that the function of the protector shall not be impaired by the corrosion and the protector can be worn as intended. Lenses and electrical components are excluded from these requirements.

### 5.2.4 Minimum Coverage Area

The frames, lens housings or carriers and lens(es) shall cover in plain view an area of not less than 40 mm (1.57 in.) in width and 33 mm (1.30 in.) in height (elliptical) in front of each eye, centered on the pupil centers of the test headform.

Frames, lens housing or carrier and lens(es) designed for small head sizes shall cover in plain view an area of not less than 34 mm (1.34 in.) in width and 28 mm (1.10 in.) in height (elliptical), centered on the pupil centers of the test headform.

Frames, lens housing or carrier and lens(es) designed for small head sizes shall be tested on the small headform. Frames that are tested using the small headform shall be marked on the frame with the letter "H."

## 5.3 Markings

### 5.3.1 Required Protector Markings

All protectors shall bear the permanent and legible markings in specified locations as shown in Table 3. Markings for lens type and use applications shall be required only when claims for protection against the hazard or indicated use are made by the manufacturer.

The components of frames that are intended for prescription protector use shall be marked for size in accordance with the system described in ANSI/ISO 7998 / 8624 / 12870. Fronts shall be

marked with the A-dimension (eye size) and DBL (distance between lenses). Temples shall be marked with their overall length.

### 5.3.2 Placement of Markings

Protector markings shall be placed in relatable proximity to each other on the product in the sequence specified below:

- Manufacturer's marks or logos
- Designation of standard (Z87 or Z87-2, for prescription devices)
- Coverage (See 5.2.4)
- Optical level (See 6.1)
- Optional Hazard-Specific Marks, as applicable:
  - impact-protector marking (+) (See 7.1)
  - optical radiation marking (See 7.2)
  - droplet and splash marking (See 7.3)
  - dust marking (See 7.4)
  - fine dust marking (See 7.5)
- Optional Design Marks, as applicable:
  - Anti-fog treatment (See 6.2)

Manufacturer's marks or logos are exempt from the proximity requirement if they are clearly present elsewhere on the product. Markings representative of other standards shall not interfere with or be intermixed with the markings required by this standard. Examples of acceptable and not acceptable product markings can be found in Annex L.

### 5.3.3 Prescription Lens Carriers

Prescription lens carriers used behind plano protectors shall be marked with the manufacturer's mark or logo but shall not be marked with other Z87 markings.

| <b>Table 3. Marking Requirements</b>   |  |                       |                          |  |
|--|--|-----------------------|--------------------------|--|
| <b>Type of Mark</b>  | <b>Lenses &amp; Replacement Lenses</b> |                       | <b>Frame<sup>1</sup></b> | <b>Marking for Complete Device (no replaceable components)<sup>2</sup></b> |
|  | <b>Spectacles</b>                      | <b>All Other</b>      |                          |  |
| All protectors shall bear the markings below.  |  |                       |                          |  |
| <b>Manufacturer's Mark or Logo</b>   | Yes                                    | Yes                   | Yes                      | Yes  |
| <b>Standard</b>  |  |                       |                          |  |
| Plano, Readers, Magnifiers   |  | <b>Z87</b>            | <b>Z87</b>               | <b>Z87</b>   |
| Rx   |  | <b>Z87</b>            | <b>Z87-2</b>             | <b>Z87-2</b>   |
| <b>Coverage</b> (small head sies) <sup>3</sup>   | <b>H</b>                               |                       | <b>H</b>                 |  |
| The following shall be required only when claims of impact rating, a specific lens type and/or use are made by the manufacturer. |  |                       |                          |  |
| <b>Impact Mark</b>   |  |                       |                          |  |
| Impact Rated Plano, Readers Magnifiers   | +                                      | <b>Z87+</b>           | <b>Z87+</b>              | <b>Z87+</b>  |
| Impact Rated Rx  | +                                      | <b>Z87+</b>           | <b>Z87-2+</b>            | <b>Z87-2+</b>  |
| <b>Relaxed Optical Level<sup>6</sup></b>   | <b>O2</b>                              | <b>O2</b>             |                          | <b>O2</b>  |
| <b>Lens Type</b>   |  |                       |                          |  |
| Clear  |  |                       |                          |  |
| Welding Filter (see table 7) <sup>5</sup>  | <b>W shade</b>                         | <b>W shade</b>        |                          | <b>W shade</b>   |
| UV Filter (see table 8) <sup>4</sup>   | <b>U scale number</b>                  | <b>U scale number</b> |                          | <b>U scale number</b>  |
| IR Filter (see table 9) <sup>4</sup>   | <b>R scale number</b>                  | <b>R scale number</b> |                          | <b>R scale number</b>  |
| Visible Light Filter (see table 10) <sup>4</sup>   | <b>L scale number</b>                  | <b>L scale number</b> |                          | <b>L scale number</b>  |
| Variable Tint  | <b>V</b>                               | <b>V</b>              |                          | <b>V</b>   |
| Special Purpose Lenses   | <b>S</b>                               | <b>S</b>              |                          | <b>S</b>   |
| Anti-Fog   | <b>X</b>                               | <b>X</b>              |                          |  |
| <b>Use</b>   |  |                       |                          |  |
| Splash / Droplet   |  |                       | <b>D3</b>                | <b>D3</b>  |
| Dust   |  |                       | <b>D4</b>                | <b>D4</b>  |
| Fine Dust  |  |                       | <b>D5</b>                | <b>D5</b>  |

- Frame components subject to marking vary by type of protector.
  - Spectacles: Frame and at least one temple. Both detachable sideshields are marked Z87+, if impact rated
  - Goggles: Frame and lens housing or carrier
  - Faceshields: Crown and chin protector
  - Welding helmets and handshields: Shell and lens housing or carrier
  - Respirators: None
  - Prescription frames: Size marking on front and temples in accordance with ANSI/ISO 7998 / 8624 / 12870
- A complete device (no replaceable components) shall have at least one set of markings. The markings may be on the lens or the frames or both the lens and the frame.
- For spectacle protectors, coverage marking "H" shall be on the lens for rimless or semi-rimless lens retention systems.
- In case of multiple filter type compliance, designations shall be listed in the order given in this table: U, R, L.
- Marks for variable ADF's shall include the range of dark states offered, e.g. "W9-12"
- Where a claim of compliance for both impact-rating and relaxed optical levels is made, it is acceptable, but not required, for the "+" marking to be placed inside of the "O", so long as both are discernible. No marking is required for standard optical levels.



## 5.4 Other Requirements

### 5.4.1 Vented Goggles

If the goggle is equipped with adjustable ventilation, the protector shall be tested in the maximum open position.

#### 5.4.1.1 Direct Ventilation

The vented portion of the goggle shall be such that the openings exclude spherical objects 1.5 mm (0.06 in.) in diameter or greater.

#### 5.4.1.2 Indirect Ventilation

The vented portion of the goggle shall be such that no direct straight-line passage from the exterior to the interior of the goggle exists.

### 5.4.2 Screen Windows and Screen Lenses

Exposed borders of screen windows and cutouts in the screen window (combination plastic and screen) shall be finished in such a manner as to eliminate any sharp, rough or unfinished edges. Screen windows and lenses are exempt from penetration and optical requirements.

### 5.4.3 Welding Protectors

#### 5.4.3.1 Cover Lenses

Cover lenses are exempt from all requirements of this standard. Cover lenses do not provide protection from optical radiation or impact. Cover lenses shall not be marked "Z87."

#### 5.4.3.2 Information Provided with Welding Protectors

A welding protector shall, as sold, be accompanied by lens and retention information. The information shall include, at a minimum:

- A list of all lens and retention components, plus the shell model.
- Information sufficient to allow the user to install the lenses in the correct order. A simple statement that the lens list is ordered from, for example, outside to inside is sufficient.
- A clear statement that the protection marked in accordance with this standard is only provided when all lens and retention components are installed according

to the list or other manufacturer's instructions.

- The nominal thickness and material type of unmarked cover lenses.

### 5.4.4 Frames for Removable Lenses

All frames which can house removable lenses shall be supplied with detailed specifications on the required lens bevel design or mounting technique and nominal lens sizing.

### 5.4.5 Minimum Lens Thickness for Prescription Spectacles

The minimum lens thickness for prescription spectacles shall be those indicated in Table 4.

| Table 4. Minimum Lens Thickness for Prescription Lenses |   |
|---|---|
| Spectacle   | $\geq 3.0$ mm (0.12 in.)<br>$\geq 2.5$ mm (0.10 in.) if power in the most plus-meridian of the distance portion is $\geq +3.00$ D |
| Spectacle, impact rated                                 | $\geq 2.0$ mm (0.08 in.)*   |

\* This requirement shall also apply to removable lenses made with a plano power to fit an impact rated prescription spectacle.

## 5.5 Replaceable Lenses

### 5.5.1 Goggles

Round lenses measuring 50 mm (1.97 in.) shall have a dimensional tolerance of  $\pm 0.2$  mm (0.008 in.).

Rectangular lenses measuring 51 x 108 mm (2.00 x 4.25 in.) shall have a dimensional tolerance of  $\pm 0.8$  mm (0.031 in.).

### 5.5.2 Welding Helmets and Handshields

Rectangular lenses measuring 51 x 108 mm (2.00 x 4.25 in.) and 114 x 133 mm (4.49 x 5.24 in.) shall have a dimensional tolerance of  $\pm 0.8$  mm (0.031 in.).

## 5.6 Aftermarket Components and Accessories

All original equipment manufacturers (OEM) and non-OEM aftermarket components or accessories not sold with the original device shall be tested assembled with the original complete device in the as-worn condition to show compliance with all applicable requirements in Sections 5, 6, 7 and 8 as claimed for the original device. For aftermarket sideshields, the sideshields shall be tested on representative frames for which the product is specified to fit. Documentation listing all devices that the component or accessory (OEM or non-OEM) has been tested and is approved for shall be made available by the manufacturer.

The entity claiming compliance of the component or accessory is responsible for testing the original complete device assembled with the components or accessories and shall provide evidence of compliance upon request.

Except for automatic darkening filters, replacement welding and goggle filters and lenses that meet the size restrictions specified in Section 5.5.2 shall be tested on one type of representative frame as needed to verify compliance with applicable requirements in Sections 5, 6, and 7.

## 6. Optional Design Characteristics

This section describes optional features that, while not protective themselves, are important to many users.

### 6.1 Relaxed Optics Level

**6.1.1** When tested in accordance with Section 9.4, protectors marked in accordance with Table 3 as having relaxed optics shall meet the requirements of Table 2 for prism and prism imbalance and Table 5 for refractive power, astigmatism and resolving power.

**6.1.2.** When tested in accordance with Section 9.2, protectors with relaxed optics shall have a luminous transmittance of not less than 78%.

### 6.2 Anti-Fog Properties

When tested in accordance with Section 9.20, the lenses of protectors marked in accordance with Table 3 as having anti-fog properties shall remain free from fogging for a minimum of 8 seconds.

NOTE: This procedure applies to lenses only and does not assess resistance to fogging of the complete device.

## 7 Optional Hazard-Specific Protector Requirements

This section describes optional requirements for protectors that are marked as providing safety and protection against various hazards as listed.

### 7.1 Impact Protector Requirements

#### 7.1.1 Protectors Marked for Impact Protection

Protectors and replaceable components marked for impact protection in accordance with Table 3 shall meet applicable requirements of Section 7.1.

#### 7.1.2 Frames and Shells

Frames and shells shall meet the requirements for high mass impact and high velocity impact in order to be impact rated. These components shall be tested as a complete device. For frames and shells to be used with prescription lenses, they shall be fitted with representative test lenses having a nominal plano power and the minimum lens thickness to be used by the manufacturer, in no case less than 2.0 mm (0.079 in.).

Frames and shells are exempt from the penetration requirement.

| <b>Table 5. Tolerance on Refractive Power, Astigmatism and Resolving Power – Relaxed Optics</b> |                         |                    |                        |
|---|-------------------------|--------------------|------------------------|
| <b>Protector</b>  | <b>Refractive Power</b> | <b>Astigmatism</b> | <b>Resolving Power</b> |
| Spectacle, Reader   | $\pm 0.13$ D            | $\leq 0.13$ D      | Pattern 17             |
| Goggle, Full-facepiece respirator   | $\pm 0.13$ D            | $\leq 0.13$ D      | Pattern 17             |
| Faceshield windows, Loose-fitting respirator  | No requirement          | No requirement     | Pattern 17             |
| Welding helmet lenses   | $\pm 0.13$ D            | $\leq 0.13$ D      | Pattern 17             |

### 7.1.3 Lateral (Side) Coverage

When tested in accordance with Section 9.10, impact rated protectors shall provide continuous lateral coverage (i.e. no openings greater than 1.5 mm (0.06 in.) in diameter) from the vertical plane of the lenses tangential to a point not less than 10 mm (0.39 in.) posterior to the corneal plane and not less than 10 mm (0.39 in.) in height (or 8 mm (0.32 in.) for the smaller headform) above and not less than 10 mm (0.39 in.) in height (or 8 mm (0.32 in.) for the smaller headform) below the horizontal plane centered on the eyes of the headform. The probe shall not contact the headform within the defined coverage area. (See Annex D).

### 7.1.4 Impact Requirements

#### 7.1.4.1 Protector Acceptance Criteria

When each type test is conducted as indicated in Sections 7.1.4.2, 7.1.4.3 and 7.1.4.4 and, as applicable Section 7.1.4.6, a complete device shall fail if any of the following occurs:

- any part, fragment or material visible to the unaided eye becomes detached from the inner surface of any complete device, as determined by inspection of the device or of the contact paste;
- fracture;
- penetration of the inner surface either by the projectile passing completely through the lens, frame or housing component, or by rupture of the inner lens surface;
- lens not retained;
- for the high-velocity test, the unaided eye ob-

serves any piece adhering to the contact paste, or observes contact paste on the projectile or complete device.

For the device to fail high mass impact, the above-listed effect(s) must occur on the first/ initial hit of the projectile on the device. Any effects to the device from subsequent “bounce” hits or from the rearward end of the high mass impact projectile striking the device shall be ignored. The evaluator is responsible for determining whether an effect was caused by a second bounce or rearward end of the high mass projectile.

In the case of plano protectors with a prescription lens carrier, contact of the prescription lens carrier with the headform does not constitute a failure.

#### 7.1.4.2 High Mass Impact

When tested in accordance with Section 9.11, the complete device shall meet the protector acceptance criteria when impacted by a pointed projectile weighing a minimum of 500 g (17.6 oz) dropped from a height of at least 127 cm (50.0 in.).

#### 7.1.4.3 High Velocity Impact

When tested in accordance with Section 9.12, the complete device shall meet the protector acceptance criteria when impacted by either steel ball traveling at its respective velocities specified in Table 6.

| <b>Table 6. High Velocity Impact Testing</b>   |   |   |
|--|---|---|
| <b>Device type</b>   | <b>Minimum Velocity</b>                       |   |
|  | <b>6.35 mm (0.25 in.) diameter steel ball</b> | <b>6.00 mm (0.24 in.) diameter steel ball</b> |
| Welding helmets  | 45.7 m/s<br>(150 ft/s)                        | 50.9 m/s<br>(167 ft/s)                        |
| Spectacles<br>Readers<br>Magnifiers  | 45.7 m/s<br>(150 ft/s)                        | 50.9 m/s<br>(167 ft/s)                        |
| Goggles<br>Full facepiece respirators  | 76.2 m/s<br>(250 ft/s)                        | 84.7 m/s<br>(278 ft/s)                        |
| Faceshields<br>Loose-fitting respirators   | 91.4 m/s<br>(300 ft/s)                        | 101.5 m/s<br>(333 ft/s)                       |
| NOTE: The paired velocities and ball diameters are designed to provide impacts of comparable kinetic energy. |   |   |

#### 7.1.4.4 Penetration Test (lenses only)

When tested in accordance with Section 9.13, lenses for all complete devices shall meet the protector acceptance criteria when penetrated by a weighted needle with minimum a total weight of 44.2 g (1.56 oz) dropped from a height of at least 127 cm (50.0 in.).

#### 7.1.4.5 Prescription Lens Material Qualification

When tested in accordance with Section 9.14, representative test lenses for use in prescription protectors shall be capable of resisting impact from either a 6.0 mm (0.24 in.) or a 6.35 mm (0.25 in.) diameter steel ball traveling at the respective velocities specified in Table 6.

When tested in accordance with this section, the lens shall fail if any of the following occurs:

- posterior displacement of the lens completely through the test holder;
- fracture of the lens;
- any detachment of a portion of the lens from its inner surface; or
- any full thickness penetration of a lens.

Failure of any lens constitutes a failure. If all test lenses pass, then any prescription lens of the same or greater thickness at its thinnest point,

which is made by the same manufacturer, from the same material, with the same coatings and processes may bear the “+” mark.

#### 7.1.4.6 Prescription Lens Mounting Qualification

When tested in accordance with Section 9.11 and Section 9.12 complete devices using representative test lenses meeting the requirements of Section 7.1.4.5 and having the thinnest lens thickness to be used by the manufacturer, in no case less than 2.0 mm (0.079 in.), shall be capable of resisting high mass and high velocity impact. For each type of lens retention system offered for sale, one set of ten (10) complete devices shall be tested, (six (6) high velocity and four (4) high mass). Failure of any one device as a result of tests shall constitute failure for a set.

Lens retention systems are:

- Full rim eyewires that require bevel designs like a “safety V bevel and other lens bevels” for metal frames.
- Full rim eyewires that require bevel designs like a “safety V bevel and other lens bevels” for plastic frames.
- Grooved metal frame style (T-Eyewire).
- Grooved semi rimless with half metal rim and suspension cord mountings.
- Three-piece rimless drill mount.
- Any mounting that is configured differently than described above to secure the lens and that is design/process dependent such that it requires a different lens beveling process or mounting technique.

Manufacturers shall also conduct the test if it incorporates frames with different lens retention systems into the product offering.

This type testing shall be performed when any substantive change in production occurs that could affect the ability of the device to pass the tests as described in Sections 9.11 and 9.12.

#### 7.1.4.7 Devices with Lift Fronts

Complete devices with lift fronts shall meet the applicable requirements of Section 7.1 with the lift front in the “up” position.

## 7.2 Optical Radiation Protector Requirements

The following requirements apply to protectors for which filtration of optical radiation is claimed including welding, ultraviolet, infrared and visible light filters. Claimed transmittance characteristics of a protector shall be marked in accordance with Tables 7, 8, 9 and 10 using a letter marking and a scale/shade number indicated the ability to filter optical radiation. Special purpose filters shall meet the requirements of Table 11.

### 7.2.1 Protectors with Clear Lenses

When tested in accordance with Section 9.2, clear plano, reader, magnifier and prescription lenses shall have a luminous transmission of not less than 85%. Representative test lenses of plano power may be substituted for prescription, reader or magnifier lenses in this test.

### 7.2.2 Protectors Providing Filtration of Optical Radiation

#### 7.2.2.1 Filter Lenses

##### 7.2.2.1.1 Transmission Requirements

When tested in accordance with Section 9.2, plano, reader, magnifier and prescription lenses that are marked as filtering optical radiation shall comply with requirements of Table 7 (welding filters), Table 8 (ultraviolet filters), Table 9 (infrared filters), Table 10 (visible light filters) and/or Table 11 (special purpose filters). Special purpose filters may or may not comply with Tables 8, 9 or 10, but shall comply with the requirements of Table 11 for special purposes.

Lenses shall meet the claimed transmittance criteria throughout their entire geometry apart from 5 mm (0.20 in.) from the lens edge. Changes in transmittance due to thickness variation in decentered/ side protective wrap around lenses are permitted so long as the variation in transmittance is not greater than one shade/scale number less than that claimed for the filter lens. Lenses shall be tested (at minimum) at points directly in front of each eye and at the thinnest thickness of the lens not within 5 mm (0.20 in.) from the lens edge.

Representative test lenses of plano power may be substituted for prescription, reader or magnifier lenses in this test.

##### 7.2.2.1.2 Visible Light Filters

When tested in accordance with Section 9.2, visible light filters, including photochromic and mechanical or manual adjustment types, shall meet the requirements and be marked in accordance with Table 9.

Visible light filters in the range of L1.3 through L3 shall also meet the transmittance requirements of Table 4 of ANSI Z80.3-2018, including traffic signal recognition and UV transmittance (high and prolonged exposure). Visible light filters in the range of L4 through L10 are too dark to be used for driving, but shall meet the UV transmittance (high and prolonged exposure) requirements of Table 4 of ANSI Z80.3-2018

Lenses shall meet the claimed transmittance criteria throughout their entire geometry apart from 5 mm (0.20 in.) from the lens edge. Changes in transmittance due to thickness variation in decentered/ side protective wrap around lenses are permitted so long as the variation in transmittance is not greater than one shade/scale number less than that claimed for the filter lens. Lenses shall be tested (at minimum) at points directly in front of each eye and at the thinnest thickness of the lens not within 5 mm (0.20 in.) from the lens edge.

##### 7.2.2.1.3 Variations in Luminous Transmittance

Measurements shall be taken according to Section 9.2.

For shades 1.3 through 3.0, the ratio of the two measured transmittances, one for each lens of a removable pair, or at points directly in front of each eye for a non-removable lens, shall not be less than 0.90, nor more than 1.11.

For shades 4.0 through 16 inclusive, the ratio of the two measured transmittances shall be not less than 0.80 nor more than 1.25. Variation in transmission shall be measured in the darkest state.

For prescription lenses, readers and magnifiers, the same requirements apply, except when variations are due to thickness variations based on the lens design.

### 7.2.2.2 Transmittance of Non-Lens Components

When tested in accordance with Section 9.2, non-lens components shall comply with the requirements of Tables 7, 8 and 9. Frames/housings that provide protection only against visible light per Table 10 are exempt from transmittance requirements. Specifically:

- Spectacles: Frames/housings of spectacles are exempt from frame transmittance requirements. Sideshields shall comply with the requirements of the applicable Tables 7, 8 and 9.
- Goggles: Frames/housings of goggles, including those with non-removable lenses, shall comply with the requirements of Tables 7, 8 and 9 according to the maximum scale number of the lens with which they will be fitted.
- Faceshields: Frames/housings of faceshields are exempt from frame transmittance requirements.
- Welding helmets: The non-lens area of welding helmets with replaceable lenses shall transmit no more optical radiation than that permitted by Table 7 for shade number 14. Non-lens areas of welding helmets with non-replaceable lenses shall transmit no more optical radiation than that of the lens.

When tested in accordance with Section 9.9, there shall be no penetration of direct visible light in all non-lens areas including the space between the lens and lens housing or carrier.

## 7.2.3 Automatic Darkening Welding Filter Lenses

### 7.2.3.1 Luminous Transmittance

Automatic darkening welding filter lenses shall meet the luminous transmittance requirements of Table 7 when tested in both the darkest and light-

est designated (marked) dark states in accordance with Section 9.2. Tests for luminous transmittance shall be performed at temperatures of:

- $-5^{\circ}\text{C} \pm 2^{\circ}\text{C}$  ( $23^{\circ}\text{F} \pm 3.6^{\circ}\text{F}$ );
- $23^{\circ}\text{C} \pm 2^{\circ}\text{C}$  ( $73.4^{\circ}\text{F} \pm 3.6^{\circ}\text{F}$ ); and
- $55^{\circ}\text{C} \pm 2^{\circ}\text{C}$  ( $131^{\circ}\text{F} \pm 3.6^{\circ}\text{F}$ ).

The dark-state shade tolerance is +/- one integer from the marked shade.

NOTE: As an example to above requirement, the tolerance for dark-state Shade 10 is Shade 9.0 (not 8.5) at minimum and Shade 11.0 (not 11.5) as a maximum.

### 7.2.3.2 UV/IR Transmittance

When measured in the lightest state, automatic darkening welding filters shall meet the requirements for UV and IR as specified in Table 7, for their designated darkest state. Measurements shall be taken in accordance with Section 9.2. UV and IR filters shall be assembled within the automatic darkening lens assembly in such a manner that they are not removable by the user.

Tests for UV and IR transmittance shall be performed in the lightest state of the filter (powered or unpowered) at a temperature of  $23^{\circ}\text{C} \pm 2^{\circ}\text{C}$  ( $73.4^{\circ}\text{F} \pm 3.6^{\circ}\text{F}$ ).

### 7.2.3.3 Switching Index

When tested in accordance with Section 9.15, the switching index from the lightest state of the automatic darkening welding filters to the darkest state of the device shall meet the requirements of Table 12 when tested at temperatures of:

- $-5^{\circ}\text{C} \pm 2^{\circ}\text{C}$  ( $23^{\circ}\text{F} \pm 3.6^{\circ}\text{F}$ );
- $23^{\circ}\text{C} \pm 2^{\circ}\text{C}$  ( $73.4^{\circ}\text{F} \pm 3.6^{\circ}\text{F}$ ); and
- $55^{\circ}\text{C} \pm 2^{\circ}\text{C}$  ( $131^{\circ}\text{F} \pm 3.6^{\circ}\text{F}$ ).

| <b>Table 7. Transmittance Requirements for Welding Filters</b> |                               |                  |                  |  |   |
|--|-------------------------------|------------------|------------------|--|---|
| <b>Shade</b>   | <b>Luminous Transmittance</b> |                  |                  | <b>Maximum Effective Far-Ultraviolet Average Transmittance %</b> | <b>Maximum Infrared Average Transmittance %</b> |
|  | <b>Maximum %</b>              | <b>Nominal %</b> | <b>Minimum %</b> |  |   |
| W1.3   | 85                            | 74.5             | 67               | 0.1  | <30   |
| W1.5   | 67                            | 61.5             | 55               | 0.1  | 25  |
| W1.7   | 55                            | 50.1             | 43               | 0.1  | 20  |
| W2.0   | 43                            | 37.3             | 29               | 0.1  | 15  |
| W2.5   | 29                            | 22.8             | 18.0             | 0.1  | 12  |
| W3.0   | 18.0                          | 13.9             | 8.50             | 0.07   | 9.0   |
| W4   | 8.50                          | 5.18             | 3.16             | 0.04   | 5.0   |
| W5   | 3.16                          | 1.93             | 1.18             | 0.02   | 2.5   |
| W6   | 1.18                          | 0.72             | 0.44             | 0.01   | 1.5   |
| W7   | 0.44                          | 0.27             | 0.164            | 0.007  | 1.3   |
| W8   | 0.164                         | 0.100            | 0.061            | 0.004  | 1.0   |
| W9   | 0.061                         | 0.037            | 0.023            | 0.002  | 0.8   |
| W10  | 0.023                         | 0.0139           | 0.0085           | 0.001  | 0.6   |
| W11  | 0.0085                        | 0.0052           | 0.0032           | 0.0007   | 0.5   |
| W12  | 0.0032                        | 0.0019           | 0.0012           | 0.0004   | 0.5   |
| W13  | 0.0012                        | 0.00072          | 0.00044          | 0.0002   | 0.4   |
| W14  | 0.00044                       | 0.00027          | 0.00016          | 0.0001   | 0.3   |
| W15  | 0.00016                       | 0.00010          | 0.000061         | 0.00007  | 0.2   |
| W16  | 0.000061                      | 0.000037         | 0.000023         | 0.00004  | 0.1   |

## NOTES:

- (1) The near-ultraviolet average transmittance shall be less than one tenth of the minimum allowable luminous transmittance for the associated shade number.
- (2) The blue light transmittance shall be less than the measured luminous transmittance.

| <b>Table 8. Transmittance Requirements for Ultraviolet Filter Lenses</b> |   |  |
|--|---|--|
| <b>Scale</b>   | <b>Maximum Effective Far-Ultra-Violet Average Transmittance %</b> | <b>Maximum Near Ultra-Violet Average Transmittance %</b> |
| U2   | 0.1   | 3.7  |
| U2.5   | 0.1   | 2.3  |
| U3   | 0.07  | 1.4  |
| U4   | 0.04  | 0.5  |
| U5   | 0.02  | 0.2  |
| U6   | 0.01  | 0.1  |

| <b>Table 9. Transmittance Requirements for Infrared Filter Lenses</b> |   |
|---|---|
| <b>Scale</b>  | <b>Maximum Infrared Average Transmittance %</b> |
| R1.3  | <30   |
| R1.5  | 25  |
| R1.7  | 20  |
| R2  | 15  |
| R2.5  | 12  |
| R3  | 9   |
| R4  | 5   |
| R5  | 2.5   |
| R6  | 1.5   |
| R7  | 1.3   |
| R8  | 1.0   |
| R9  | 0.8   |
| R10   | 0.6   |

| <b>Table 10. Luminous Transmittance requirements for Visible Light Filters</b> |                  |                  |                  |
|--|------------------|------------------|------------------|
| <b>Scale</b>   | <b>Maximum %</b> | <b>Nominal %</b> | <b>Minimum %</b> |
| L1.3   | 85               | 74.5             | 67               |
| L1.5   | 67               | 61.5             | 55               |
| L1.7   | 55               | 50.1             | 43               |
| L2   | 43               | 37.3             | 29               |
| L2.5   | 29               | 22.8             | 18               |
| L3   | 18               | 13.9             | 8.5              |
| L4   | 8.5              | 5.18             | 3.16             |
| L5   | 3.16             | 1.93             | 1.18             |
| L6   | 1.18             | 0.72             | 0.44             |
| L7   | 0.44             | 0.27             | 0.164            |
| L8   | 0.164            | 0.10             | 0.061            |
| L9   | 0.061            | 0.037            | 0.023            |
| L10  | 0.023            | 0.0139           | 0.0085           |

| <b>Table 11. Transmittance Requirements for Special-Purpose Lenses</b> |                               |                  |  |
|--|-------------------------------|------------------|--|
| <b>Lens Type</b>   | <b>LUMINOUS TRANSMITTANCE</b> |                  | <b>*Ratio [R] of measured Luminous Transmittance</b> |
|  | <b>% Maximum</b>              | <b>% Minimum</b> |  |
| Tinted   | <100                          | 8                | $0.90 \leq R \leq 1.10$                              |
| Extra Dark   | <8                            | 0.2              | $0.8 \leq R \leq 1.20$                               |

\*R is the ratio of the two measured transmittances, one for each lens of a pair, or at points directly in front of each eye for a single lens.



| Table 12. Switching Index Requirements for Automatic Darkening Welding Filter Lenses |                              |      |      |     |      |      |     |
|--|------------------------------|------|------|-----|------|------|-----|
|  | LIGHT SHADE NUMBER           |      |      |     |      |      |     |
|  | 1.7                          | 2.0  | 2.5  | 3.0 | 4.0  | 5.0  | 6.0 |
| DARK SHADE NUMBER  | Maximum Switching Index (ms) |      |      |     |      |      |     |
| W7   | 300                          | 400  | 500  | 700 | 1000 | -    | -   |
| W8   | 100                          | 150  | 200  | 300 | 500  | 1000 | -   |
| W9   | 40                           | 50   | 70   | 100 | 200  | 400  | 700 |
| W10  | 20                           | 20   | 30   | 40  | 70   | 100  | 300 |
| W11  | 6                            | 7    | 10   | 15  | 30   | 50   | 100 |
| W12  | 2                            | 3    | 4    | 5   | 10   | 20   | 40  |
| W13  | 0.8                          | 1    | 1.5  | 2   | 4    | 7    | 10  |
| W14  | 0.3                          | 0.4  | 0.5  | 0.7 | 1    | 3    | 5   |
| W15  | 0.10                         | 0.15 | 0.2  | 0.3 | 0.5  | 1    | 2   |
| W16  | 0.04                         | 0.05 | 0.07 | 0.1 | 0.2  | 0.4  | 0.7 |

#### 7.2.3.4 Occlusion

When tested in accordance with Section 9.15, automatic darkening welding filters shall meet the requirements of Table 12 when tested at temperatures of:

- $-5^{\circ}\text{C} \pm 2^{\circ}\text{C}$  ( $23^{\circ}\text{F} \pm 3.6^{\circ}\text{F}$ );
- $23^{\circ}\text{C} \pm 2^{\circ}\text{C}$  ( $73.4^{\circ}\text{F} \pm 3.6^{\circ}\text{F}$ ); and
- $55^{\circ}\text{C} \pm 2^{\circ}\text{C}$  ( $131^{\circ}\text{F} \pm 3.6^{\circ}\text{F}$ ).

This shall be true regardless of which sensor or sensors are occluded.

#### 7.2.3.5 Angular Dependence of Luminous Transmittance

When tested in accordance with Section 9.16, the values of  $V_{15}$  and  $V_{30}$  of automatic welding filters shall not exceed the values in Table 13 when tested at a temperature of  $23^{\circ}\text{C} \pm 5^{\circ}\text{C}$  ( $73^{\circ}\text{F} \pm 9^{\circ}\text{F}$ ).

The requirement shall apply to the dark state.

| Table 13. Angular dependence of luminous transmittance |   |
|--|---|
| $V_{15}$   | $V_{30}$                                  |
| 19.31<br>(corresponding to 3 scale numbers)            | 138.95 (corresponding to 5 scale numbers) |

### 7.3. Droplet and Splash, Dust, and Fine Dust Protection Requirements

#### 7.3.1 Goggles

When tested in accordance with Section 9.17.1, the droplets and/or liquid splash shall not cause a red coloration within either of the two circles described in the test method.

#### 7.3.2 Faceshields

When tested in accordance with Section 9.17.2, the laser beam shall not make direct contact with any point on the eye-region rectangle without first being intercepted by the faceshield.

#### 7.4 Dust Hazard

When tested in accordance with Section 9.18, the ratio of the mean reflectance after exposure in the dust chamber to the mean reflectance before exposure shall not be less than 0.80.

#### 7.5 Fine Dust Hazard

When tested in accordance with Section 9.19, no red coloration shall be observed within either of the two circles described in the test method.

## 8. RESERVED FOR FUTURE USE

## 9. Test Methods

Testing shall be performed on the number of complete devices specified within the test sections below and summarized in Annex A. Unless otherwise specified, all testing shall be performed at a standard laboratory temperature of  $23 \pm 5^{\circ}\text{C}$  ( $73 \pm 9^{\circ}\text{F}$ ). If there is disagreement in the test results among different laboratories, the protector shall be re-tested at a controlled relative humidity of  $50 \pm 15\%$ .

In many tests, devices are mounted on one of two headforms of the type defined by EN 168:2001, Section 17 and referenced in Annex B. When testing a protector, the appropriate sized headform (medium or small) shall be used throughout the testing protocol.

Alternative measurement methods are acceptable if shown to perform equivalently to the reference test methods cited in this section.

### 9.1 Optical Quality Test

#### 9.1.1 Purpose

This test is intended to determine that the lenses are free of visible defects which would impair their optical quality.

#### 9.1.2 Apparatus and Procedure

The apparatus and procedures specified in ANSI Z80.1-2015 shall be used to determine the lenses optical quality. All lenses of one complete device shall be tested.

### 9.2 Transmittance Test

#### 9.2.1 Purpose

This test is intended to measure the ultraviolet, luminous, infrared and blue-light, normal transmittance of lenses.

#### 9.2.2 Apparatus and Procedure

The transmittance may be determined by any suitable method, but the reference method shall be the use of a spectrophotometer and calculation using appropriate weighting factors given in Ta-

bles C1 through C4 of Annex C. All lenses of one complete device shall be tested.

### 9.3 Haze Test

#### 9.3.1 Purpose

This test is intended to measure the haze in clear lenses.

#### 9.3.2 Apparatus and Procedure

The apparatus and procedures specified in ASTM D1003-13 shall be used to measure the haze. The illuminant used shall be CIE illuminant A. All lenses of one complete device shall be tested.

### 9.4 Refractive Power, Astigmatism and Resolving Power Tests

#### 9.4.1 Purpose

These tests are intended to determine that the protectors meet the optical requirements for refractive power, astigmatism and resolving power of this standard.

#### 9.4.2 Apparatus

The apparatus shall consist of a calibrated 8 power telescope (preferably with a reticle) having a minimum aperture of 19 mm (0.75 in.) for plano-spherical lenses and a minimum aperture of 7 mm (0.28 in.) for plano-toric or plano-aspheric lenses, a means of holding the protector in the test position, and the combined sunburst and resolution test pattern (See Figure E5). The test pattern shall be mounted 10.67 m (35 ft) from the objective lens of the telescope and have sufficient lighting, backlit or otherwise, to properly conduct the test.

Calibration methods for the telescope are given in Annex F.

#### 9.4.3 Procedure for Refractive Power and Astigmatism

The telescope and observer shall be qualified by resolving pattern 40 of the test pattern when no lens is in front of the telescope. The telescope shall then be focused on the radial lines of the test pattern. Except for faceshield windows, the lens shall be positioned as worn with the primary line of sight coincident with the axis of the telescope. For faceshield windows, the holder shall be positioned such that the axis of the telescope passes

without occlusion through the window. Testing of autodarkening filters shall be done in the light state. All lenses of one complete device shall be tested. Either surface of the test lens can be presented to the objective lens of the telescope and both the left and right viewing areas of eyewear shall be tested.

The distance between the lens being tested and the objective lens of the telescope shall not exceed 38 mm (1.5 in.). The telescope is then re-focused on the radial lines until they appear as sharp as possible. Two possibilities may then occur, all or just some of the lines will appear well-focused.

If all radial lines appear equally well-focused at the same position of the focus wheel, the lens has no measurable astigmatism and the power reading of the telescope is the refractive power of the test lens.

If lines in only one meridian appear sharpest at a given focus, then the telescope shall be re-focused to determine the best focus for the lines in the meridian which yield an extreme (maximum or minimum) power reading. The power reading shall be noted. The telescope shall be then re-focused for lines in the meridian which yields the opposite extreme power reading. The second power reading shall be noted. (See Figure G1). The mean refractive power of lenses with astigmatism is the average of the maximum and minimum power readings obtained. The astigmatism shall be calculated as the absolute value of the algebraic difference between the two extreme power readings.

#### 9.4.4 Procedure for Resolution Testing

Once the refractive and astigmatic readings have been determined, re-focus the telescope on the test target for the best compromise focus, that is, until all radial lines appear equally sharp. The observer shall attempt to resolve all lines of pattern 20 (or pattern 17 for protectors assessed at the relaxed optical level) in both orientations without re-focusing the telescope. To resolve all lines of a pattern is to simultaneously identify that 3 discernible lines exist in both the vertical and horizontal axis of the same pattern designation (See Figures G2 and G3).

## 9.5 Prismatic Power Test

### 9.5.1 Purpose

This test is intended to measure the prismatic power and prismatic imbalance of a protector.

### 9.5.2 Apparatus

This apparatus shall consist of the headform which has been modified by boring two through holes at least 19.0 mm (0.75 in) diameter centered on each eye. The headform shall be placed in an optical system as shown in Figure E6. The telescope lens, L2, shall be located at a distance of 1.00 m (39.4 in.) in front of image plane, IP. The pinhole aperture plate, p, shall be located approximately 1.00 m (39.4 in.) from the collimator lens, L1, and shall be adjusted so that one image is formed on the image plane, IP, when no protector is on the headform. The position of that image shall be marked or noted and will be called Po.

### 9.5.3 Procedure

The complete device shall be placed on the headform in the designed wearing position, without having changed the spacing of the optical system. The image(s) on the image plane shall be identified as coming from the right eye, Pr, or the left eye, Pl, by blocking the beams of each eye. The distance in centimeters between the centers of Pl and Po and Pr and Po shall be measured. The prismatic power of the protector in prism diopters ( $\Delta$ ) is determined by measuring the distance in centimeters between Po and Pl or Po and Pr, whichever is greater. The horizontal and vertical distances in centimeters between the centers of Pl and Pr shall be measured.

The horizontal prism imbalance of the protector in prism diopters shall be the horizontal distance measured in centimeters between Pl and Pr. The vertical prism imbalance of the protector in prism diopters shall be the vertical distance measured in centimeters between Pl and Pr. The “base” of the horizontal prism imbalance shall be determined by looking at the image plane (looking at the image plane from the headform). If the right-most image comes from the right eye of the headform, then the prism imbalance is “base out”. If the left-most image comes from the right eye of the headform, then the prism imbalance is “base in”. One

complete device shall be tested.

## 9.6 Drop Ball Test

### 9.6.1 Purpose

This test is intended to ensure that all protectors possess a minimum impact resistance.

### 9.6.2 Apparatus

The headform shall be used to hold the complete device. The headform shall be rigidly mounted in the horizontal position, face up, on a base which has a mass of not less than 30 kg (66 lb). The static stiffness of the headform shall be such that when a vertical force of 20 kg (44 lb) is applied to the forehead of the headform, the back of the headform shall not deflect by more than 2 mm (0.08 in.). The projectile is a 25.4 mm (1.0 in.) diameter steel ball, weighing 68 g (2.4 oz), and it shall be guided from the test height of 127 cm (50 in.) through a loose fitting guide tube having a smooth internal diameter ending 0.1 m (4 in.) above the point of contact.

### 9.6.3 Procedure

Each complete device tested shall be placed on the headform as it would be worn by the user. For faceshields, an additional supporting block, approximately 25 mm (1 in.) wide and curved to conform to the shape of the window, shall be provided as a support for the window at its lower end but not lower than the chin of the headform. The alignment shall be such that when the ball is dropped, it is in line with either of the eyes of the headform.

A 25.4 mm (1.0 in.) diameter steel ball, weighing 68 g (2.4 oz) shall be freely dropped from a height of 127 cm (50 in.) onto the lens at a point in line with the eyes of the headform. Four (4) complete devices shall be tested for each lens material and coating, two on the left viewing area and two on the right viewing area.

## 9.7 Ignition Test

### 9.7.1 Purpose

This test is intended to determine the protector's resistance to ignition as worn.

### 9.7.2 Apparatus

The test apparatus shall consist of a steel rod measuring 300 (11.81 in.) long and 6 mm (0.24 in.) in diameter with end faces that are flat and cut perpendicular to the longitudinal axis, a heat source capable of temperatures of at least 650°C (1202°F), a thermocouple and temperature indicating device, and a timer with 0.1s accuracy.

### 9.7.3 Procedure

Attach the thermocouple to the rod at a distance of  $20 \pm 1$  mm ( $0.79 \pm 0.04$  in.) from the end of the rod. Heat that end of the steel rod over a minimum length of 50 mm (1.97 in.) to a temperature of  $650 \pm 20$  °C ( $1202 \pm 36$  °F).

Press the heated face of the rod against a surface of the protector (the contact force being equal to the weight of the rod) for  $5.0 \pm 0.5$  seconds, and then remove it.

Repeat with each additional externally exposed part of the protector as worn, until all external surface materials (excluding metals, elastic bands or textiles) have been tested. One complete device shall be tested.

## 9.8 Corrosion Resistance Test

### 9.8.1 Purpose

This test is intended to determine the capability of metal components of a protector to resist corrosion.

### 9.8.2 Apparatus

The test apparatus shall consist of a boiling saline solution and a room temperature saline solution both in containers of sufficient dimensions to submerge the metal parts. The saline solutions shall contain 10% by weight of sodium chloride in water prior to heating.

### 9.8.3 Procedure

Metal parts shall be submerged in the boiling saline solution for a period of 15 minutes. Upon being removed from the boiling solution, the parts shall be immediately immersed in the room temperature saline solution. They shall then be removed from this solution, and without having the adhering liquid wiped off, allowed to dry for twenty-four hours at room temperature. The

metal parts shall then be rinsed in lukewarm water and allowed to dry. One complete device shall be tested.

## 9.9 Light Tightness Test

### 9.9.1 Purpose

This test is intended to determine light sealing capabilities between the lens and the lens holder of welding protectors.

### 9.9.2 Apparatus

The apparatus shall consist of a system capable of illuminating the entire lens retaining area and confining the light to the exterior surface of the protector. An example is shown in Figure E3.

The device shall be fitted with a shade 14 lens for this test. Automatic darkening filter lenses shall be tested with the viewing area covered with an opaque material.

### 9.9.3 Procedure

The welding protector shall be held firmly against the seal of the test apparatus and examined for direct light leakage between the lenses, gaskets or other components. The test shall be performed in a darkened room to verify a light tight design when viewed from any angle. One complete device shall be tested.

## 9.10 Lateral Protection Test

### 9.10.1 Purpose

The test is intended to assess the lateral protection area of a complete device.

### 9.10.2 Apparatus

The apparatus shall consist of the headform mounted vertically and a probe device such as a rod of 1.5 mm (0.06 in.) diameter, 125 mm (4.9 in.) long. Other suitable probes may be used, but this is the reference method. Protectors marked with an "H" or intended for smaller anatomical dimension shall be tested on the smaller headform.

### 9.10.3 Procedure

The complete device shall be placed on the headform in the designated wearing position. The probe shall be directed horizontally to contact six (6) lateral positions on the complete device:

- a. Anywhere within the coverage area defined in Section 7.1.3 and including a point 10 mm (0.39 in.) above (8 mm (0.32 in.) above for the smaller headform) the horizontal plane at 90° (temporal) to each eye (three test locations).
- b. Anywhere within the coverage area defined in Section 7.1.3 and including a point 10 mm (0.39 in.) below (8 mm (0.32 in.) below for the smaller headform) the horizontal plane at 90° (temporal) to each eye (three test locations).

One complete device shall be tested.

## 9.11 High Mass Impact Test

### 9.11.1 Purpose

This test is intended to determine the capability of a protector to resist impact from relatively heavy, pointed objects traveling at low velocity.

### 9.11.2 Apparatus

The headform shall be used to hold the complete device. The headform shall be rigidly mounted in the horizontal position, face up, on a base which has a mass of not less than 30 kg (66 lb). The static stiffness of the headform shall be such that when a vertical downward force of 20 kg (44 lb) is applied to the forehead of the headform, the back of the headform shall not deflect more than 2 mm (0.08 in.). The projectile shall be made of steel and shall have a 30° conical tip with a 3.18 mm (0.125 in.) spherical radius, shall weigh a minimum of 500 g (17.6 oz), and have a diameter of 25 mm (1.0 in.), as shown in Figure E4. The projectile will be held in position over the headform, tip down, at the designated test height of 127 cm (50.0 in.). The projectile may have a hardened steel tip. Care shall be taken to maintain the tip configuration and weight of the projectile.

The projectile shall be dropped through a loose-fitting guide tube having a smooth internal diameter; this prevents projectile tumble while not retarding free fall. The guide tube shall be positioned so that the lower end of the tube is 18 cm (7.1 in.) from the point of impact.

### 9.11.3 Procedure

Testing shall be performed on the complete protector with its non-removable lenses or representative test lenses. A new and complete device is placed on the headform as it was designed to be worn. The alignment shall be such that when the projectile is dropped, its point is in line with the center of either of the eyes of the headform. Complete devices with lift fronts shall be tested with the lift front in the “up” position.

Four (4) complete devices shall be tested within a 20 mm (0.79 in.) circle centered in front of each eye of the headform, two on the left viewing area and two on the right viewing area.

**9.11.3.1** Spectacles intended for prescription removable lenses shall be equipped with representative test lenses for testing. The representative test lenses shall have a nominal plano power, and the minimum lens thickness to be used by the manufacturer, in no case less than 2.0 mm (0.079 in.).

**9.11.3.2** For each prescription lens retention system, four complete devices shall be tested.

**9.11.3.3** For prescription lens carriers, four (4) complete devices equipped with prescription lenses mounted behind the plano lens(es) shall be tested. The carriers shall be fitted with a total of four (4) lenses of -5.0 D and a total of four lenses of +5.0 D.

## 9.12 High Velocity Impact Test

### 9.12.1 Purpose

This test is intended to determine the capability of a protector to resist impact from high velocity, low mass projectiles.

### 9.12.2 Apparatus

The test apparatus shall consist of the headform mounted vertically within an enclosure and a mechanism capable of propelling a 6.35 mm (0.25 in.) diameter steel ball weighing 1.04 g (0.037 oz) reproducibly at velocities from 45.7 to 91.4 m/s (150 to 300 ft/s) at the headform or be capable of propelling a 6.0 mm (0.24 in.) diameter steel ball weighing 0.86 g (0.030 oz) reproducibly at velocities from 50.9 to 101.5 m/s (167

to 333 ft/s). Protectors marked with an “H” or intended for smaller anatomical dimensions shall be tested on the smaller headform.

The headform shall be capable of being rotated about the vertical axis specified in Section 9.12.3 in 30° increments, from a first position which is directly normal and centered to an eye of the headform to 90° temporally. The headform shall be capable of being raised and lowered 10 mm (0.39 in) for the headform, or 8 mm (0.32 in.) for the smaller headform with respect to the horizontal reference plane formed by the center of the eyes of the headform to carry out spatial testing of frontal and temporal positions. Mass of the test headform shall be at least 4 kg (8.8 lb).

The velocity of the steel ball shall be determined at a distance not greater than 25 cm (9.8 in.) from the eye of the headform and shall have a standard deviation not exceeding 2% of the specified test velocity over a test series of 30 shots.

Information about a typical High Velocity Impact Test Apparatus is given in Annex E.

### 9.12.3 Procedure

Testing shall be performed on the complete protector with its non-removable lenses or representative test lenses. Apply a thin layer of white contact paste to each of the eyes of the headform covering an area 25 mm (1.0 in.) in diameter centered on the corneal vertex of the eye. A new and complete device shall be mounted on the headform in the manner in which the protector was designed to be worn. The headform shall be adjusted so that the path of the projectile passes through the center of the anterior surface of either of the eyes of the headform. The headform is then rotated on an axis which passes vertically at the intersection of a sagittal plane through the center of the front surface of the tested eye and a corneal (frontal) plane which is 10 mm (0.39 in.) posterior to the corneal plane which is tangent to the anterior surfaces of the eyes of the headform, and/or raised or lowered 10 mm (0.39 in.) in height or 8 mm (0.32 in.) for the smaller headform) to align with each test position. A new complete device is impacted at the test velocity as specified in Section 7.1.4.3. Complete devices with lift fronts shall be tested with the lift front in

the “up” position. The balls are damaged during impact and should be changed frequently to avoid impacts at unexpected locations and large variations in velocity.

Six (6) impact sites shall be tested for each type of protector:

- a. a point along the horizontal plane of the center of the eye of the headform, and within a 10 mm (0.39 in.) diameter circle centered directly in front of each eye of the headform. (Two total test sites)
- b. within a 5 mm (0.2 in.) diameter circle centered on a point on the horizontal plane of each eye at +30° (temporal). (Two total impact sites).
- c. within a 5 mm (0.2 in.) diameter circle centered on a point 10 mm (0.39 in.) above the horizontal plane of the eye at +90°(temporal) to one eye. If the frames are marked with an “H”, the impact point shall be within a 5 mm (0.2 in.) diameter circle centered 8 mm (0.32 in.) above the horizontal plane of the eye +90° (temporal) to one eye. (One total impact site)
- d. within a 5 mm (0.2 in.) diameter circle centered on a point 10 mm (0.39 in.) below the horizontal plane of the eye at +90°(temporal) to the opposite eye of that used in c above. If the frames are marked with an “H”, the impact point shall be within a 5 mm (0.2 in.) diameter circle centered 8 mm (0.32 in.) below the horizontal plane of the eye +90° (temporal) to the opposite eye of that used in c above. (One total impact site).

A total of six (6) complete devices shall be tested using either steel ball traveling at its respective velocities specified in Table 6 for each test set.

**9.12.3.1** Spectacles intended for prescription removable lenses shall be equipped with representative test lenses. The representative test lenses shall have the minimum lens thickness to be used by the manufacturer, in no case less than 2.0 mm (0.079 in.).

**9.12.3.2** For each prescription lens retention system, six (6) complete devices shall be tested.

**9.12.3.3** For prescription lens carriers, a new and complete device shall be used for each impact point noted above for a + 5.00 D lens and a new and complete device shall be used for each impact point noted above for a – 5.00 D lens. A total of twelve (12) devices shall be tested for prescription lens carrier frames, two devices impacted at each site.

## 9.13 Penetration Test

### 9.13.1 Purpose

This test is intended to determine the capability of a lens to resist penetration by a low mass pointed projectile.

### 9.13.2 Apparatus

The test apparatus shall consist of a pointed projectile consisting of a new 135 x 17 needle fastened into a holder, weighing 44.2 g (1.56 oz). The projectile shall be dropped through a loose-fitting guide tube having a smooth internal diameter; this prevents projectile tumble while not retarding free fall. A new needle shall be used for each drop.

The headform shall be used to hold the complete device. It shall be rigidly mounted in the horizontal position, face up, on a base which has a mass of 30 kg (66 lb) or greater. The static stiffness of the headform shall be such that when a vertical downward force of 20 kg (44 lb) is applied to the forehead of the headform, the back of the headform shall not deflect more than 2 mm (0.08 in.). For faceshields, an additional supporting block, approximately 25 mm (1.0 in.) wide and curved to conform to the shape of the window, shall be provided as a support for the window at its lower end but not lower than the chin of the headform. Shielding around the headform is required to protect the operator.

### 9.13.3 Procedure

The projectile shall be freely dropped through the guide tube, point downward, from a height of 127 cm (50 in.) onto the horizontal outer surface of the lens. Four (4) complete devices shall be tested within a 20 mm (0.788 in.) circle centered in front of each eye of the headform, two on the left viewing area and two on the right viewing area.

For faceshields, the window shall be placed in a horizontal position such that the axis of the window is horizontal and the outer surface of the window is facing upward. The projectile shall be dropped onto a point in line with the eyes of the headform.

All other complete devices shall be placed on the headform as it would be worn by the user. The alignment shall be such that when the projectile is dropped, its point is in line with either of the eyes of the headform.

## 9.14 Prescription Lenses Material Qualification Test

### 9.14.1 Purpose

This test is intended to determine the ability of prescription lens materials, combined with individual coatings and processes applied, to those materials to withstand impact from high velocity, low mass projectiles.

### 9.14.2 Procedure

Representative test lenses having a nominal plano power and a maximum base curve of 6.25 diopter, and the minimum lens thickness to be used by the manufacturer, in no case less than 2.0 mm (0.079 in.), shall be edged round with a uniform  $115^{\circ} \pm 5^{\circ}$  included angle bevel to a diameter 55.0 mm  $+0.04$  mm/ $-0.25$  mm (2.17 + 0.002/ $-0.01$  in.). Each lens shall be tested once, with a new lens used for each additional impact. Each lens shall be mounted in a steel test holder by two retaining washers so that the test lens is held firmly against the bevel of the lens holder (See Figure E7). Perform the high velocity impact test on the center of each lens with the projectile and velocity determination as specified for spectacles in Table 6.

Three (3) lenses shall be tested.

NOTE: A representative test lens with an alternative base curve may be used if a 6.25 diopter base curve is not available.

## 9.15 Switching Index Test

### 9.15.1 Purpose

This test is intended to determine the switching index of an automatic darkening filter lens which requires the measurement of luminous transmittance over time as the device is exposed to optical radiation from a test light source.

### 9.15.2 Apparatus

The following test apparatus, or an equivalent apparatus capable of determining compliance with Table 12, shall be used. The response time of the test apparatus (between 10% and 90% of recorded peak light intensity) shall be no greater than 10% of the required switching index of the lens under test. The test apparatus shall consist of a light source, detector, trigger light source and a recording device.

The light source shall be a high intensity collimated light source which, when optically coupled to an associated light detector, provides the required intensity to measure the luminous transmittance of the lens under test in its highest shade number state.

The detector shall have a calibrated photopic response, which, when coupled with an associated light source, is capable of measuring the luminous transmittance of the lens under test in its highest shade number state.

The trigger light source shall be a high intensity light source of at least 10,000 lux capable of being either electronically or mechanically switched on.

The recording device shall be a storage oscilloscope or equivalent instrument capable of recording the output of the detector, in time, and providing output functions of normal transmittance and time.

### 9.15.3 Procedure

The automatic darkening welding filter shall be maintained at the appropriate test temperature for a minimum of 2 hours before testing and during the period of test. Ambient lighting conditions during testing shall not exceed 16 lux. All but any one sensor of the automatic darkening weld-



ing filter shall be occluded with opaque material.

The automatic darkening welding filter and light detectors shall be mounted normal to the beam of illumination. Solar or photoelectric power cells shall be shielded from the transmittance light source beam.

Methods shall be employed to ensure that the temperature of the lens under test does not exceed the prescribed test temperature (For example: due to exposure from the transmittance light source).

With the transmittance light source activated, the trigger light source shall be switched to its high illumination state. The luminance variations over time, both the triggering light source at the filter and the transmittance light source through the filter, shall be recorded.

The switching index shall be calculated using the equation given in Section 3, and setting  $t=0$  as the time when the recorded trigger source illumination reached 5000 lux.

Repeat test as necessary until all sensors on the device have been tested individually (with others occluded). One complete device shall be tested.

## **9.16 Angular Dependence of Luminous Transmittance Test for Automatic Welding Filter Lenses**

### **9.16.1 Principle**

This procedure specifies the method for determining angle dependence of luminous transmittance for an automatic welding filter. The test shall measure the luminous transmittance variations within the viewing cone of angles less than  $15^\circ$  to the normal of the lens and within the viewing cone of angles less than  $30^\circ$  to the normal of the lens.

### **9.16.2 Apparatus**

Suitable method for measuring luminous transmittance, for example the method described in Section 9.2, shall be used. The parallel ray of light shall have a cross section area corresponding to the area of a circle with a diameter between 5 and 20 mm (0.2 in. and 0.79 in.).

NOTE: A marginal region 5 mm (0.2 in.) wide

around the periphery of the lens shall not be included in the measurement area.

### **9.16.3 Procedure**

All measurements are performed at the geometrical center of the lens.

Measure the luminous transmittance normal ( $90 \pm 1^\circ$ ) to the surface of the automatic welding filter lens.

Measure the luminous transmittance at an angle of incidence between  $13^\circ$ - $15^\circ$  at four orientations from the point at which the normal measurement was taken, with each orientation being approximately perpendicular to one edge of the lens: at approximately  $0^\circ$  ("north"), at approximately  $90^\circ$  ("east") at approximately  $180^\circ$  ("south"), and at approximately  $270^\circ$  ("west") from the point at which the normal measurement was taken.

Measure the luminous transmittance at an angle of incidence between  $28^\circ$ - $30^\circ$  degrees at four orientations from the point at which the normal measurement was taken, with each orientation being approximately perpendicular to one edge of the lens: at approximately  $0^\circ$  ("north"), at approximately  $90^\circ$  ("east") at approximately  $180^\circ$  ("south"), and at approximately  $270^\circ$  ("west") from the point at which the normal measurement was taken.

Identify the maximum and minimum luminous transmittance for the four measurements at  $13^\circ$ - $15^\circ$ . Calculate the ratio of the established maximum luminous transmittance value to the value of the luminous transmittance measured at normal incidence. Also calculate the ratio of the value of the luminous transmittance measured at normal incidence to the minimum luminous transmittance value. The maximum of these two values is  $V_{15}$ .

Identify the maximum luminous transmittance for the four measurements at  $28^\circ$ - $30^\circ$ . Calculate the ratio of the maximum luminous transmittance value to the value of the luminous transmittance measured at normal incidence. This ratio is  $V_{30}$ .

One lens shall be tested in the dark state.

## 9.17 Droplet and Splash Test

### 9.17.1 Goggles

#### 9.17.1.1 Purpose

This test is intended to determine the capability of the protector to prevent liquid splashes or sprays from penetrating the protector. This is not intended to evaluate the fit of the protector to the wearer's face. (See Annex K.11)

#### 9.17.1.2 Apparatus

A spray solution, 0.1 ml/L solution of sodium carbonate in water, shall be prepared and placed in a hand-operated atomizer, capable of producing fine droplets (not mist).

The detection/test area on the headform shall be defined by white blotting paper of sufficient size to cover the lens area and extend at least 20 mm (0.79 in.) beyond the periphery of the protector to be tested and marked with two circles of 40 mm (1.57 in.) diameter centered over the pupillary center. If smaller sized protectors with the "H" designation are to be tested, the smaller headform shall be used and the blotting paper is to be marked with two circles of 40 mm (1.57 in.) diameter centered over the pupillary center. Absorbent cotton lint (surgical dressing), mass per unit area  $\sim 185 \text{ g/m}^2$  (0.26 sq. in.) is used to fit the protector more securely against the headform.

For this test, a detection solution, prepared by dissolving  $5.0 \pm 0.5 \text{ g}$  ( $0.18 \pm 0.018 \text{ oz.}$ ) phenolphthalein in  $500 \pm 50 \text{ ml}$  ( $16.9 \pm 1.69 \text{ fl oz.}$ ) ethanol and adding  $500 \pm 50 \text{ ml}$  ( $16.9 \pm 1.69 \text{ fl oz.}$ ) water, shall be prepared and stirred constantly (filter if precipitate forms) to obtain  $1.0 \pm 0.1 \text{ L}$  ( $33.8 \pm 3 \text{ fl oz.}$ ) of solution.

#### 9.17.1.3 Procedure

Cover the lens region of the headform with layers of cotton lint. Dip the blotting paper in the detection solution described in Section 9.17.1.2 and shake off excess. Place the moist blotting paper over the lint, centering the circles over each eye.

Fit the protector onto the headform in the normal wearing position so that the blotting paper protrudes all around its periphery by at least 20 mm (0.79 in.). Adjust the headband to a normal de-

gree of tension. Adjust the number of layers of lint, as necessary, to ensure a good seal between the protector and the headform.

Spray the mounted protector with approximately 5 - 10 ml (0.17 - 0.34 fl oz) of the spray solution, holding the atomizer at a distance of approximately 600 mm (23.6 in.) from the headform and spraying from all directions. All the blotting paper around the periphery should turn a uniform crimson color. The blotting paper shall not be over-wetted such that it drips. Examine the blotting paper for intrusion of color into the circles. One complete device shall be tested.

### 9.17.2 Faceshields

#### 9.17.2.1 Purpose

This test is intended to determine the capability of a faceshield to keep liquid splashes or sprays from reaching the wearer's eyes by observing the area of coverage of the faceshield.

NOTE: The observation method describes the use of a laser beam; alternatively, observations may be made by viewing through a cylindrical tube fitted with cross-wires.

#### 9.17.2.2 Apparatus

A headform shall be used and marked with the rectangle ABCD around the eye area as shown in Figure B1.

The marked headform shall be mounted on a stage that allows at least  $45^\circ$  rotation about the horizontal axis positioned at the level of the eyes of the headform, and at least  $90^\circ$  rotation left and right around a vertical axis centered between the eyes of the headform. An exemplary stage for mounting and rotation is shown in Figure E8.

A visible laser beam with a maximum beam diameter of 5 mm (0.20 in.) is used as the light source for observation. The laser shall be mounted to allow vertical movement up or down but no rotation about its horizontal or vertical axes.

#### 9.17.2.3 Procedure

Position the laser beam to intersect the headform at the mid-point of the horizontal line joining the eye centers. Temporarily block the laser beam

and fit the faceshield onto the headform in accordance with the manufacturer's instructions.

Project the laser beam at all accessible points within the eye-region rectangle when the headform is set to the following positions:

- 1) Headform facing forward and rotated  $45^\circ \pm 1^\circ$  forward about the horizontal axis.
- 2) Headform facing forward and rotated  $45^\circ \pm 1^\circ$  backward about the horizontal axis.
- 3) Headform rotated  $90^\circ + 1^\circ$  to the left about the vertical axis, and rotated  $45^\circ \pm 1^\circ$  forward about the horizontal axis.
- 4) Headform rotated  $90^\circ + 1^\circ$  to the left about the vertical axis, and rotated  $45^\circ \pm 1^\circ$  backward about the horizontal axis.
- 5) Headform rotated  $90^\circ + 1^\circ$  to the right about the vertical axis, and rotated  $45^\circ \pm 1^\circ$  forward about the horizontal axis.
- 6) Headform rotated  $90^\circ + 1^\circ$  to the right about the vertical axis, and rotated  $45^\circ \pm 1^\circ$  backward about the horizontal axis.

Observe whether the beam is intercepted by the faceshield before it makes contact with any point on the eye-region rectangle. Record as a failure any location where laser beam contacts the rectangle without first intercepting the faceshield.

## 9.18 Dust Test

### 9.18.1 Purpose

This test is intended to determine the capability of the protector to keep large dust particles from reaching the wearer's eyes. This is not intended to evaluate the fit of the protector to the wearer's face. (See Annex K.11)

### 9.18.2 Apparatus

An enclosed dust chamber with glass front and nominal dimensions of 56 x 56 x 56 cm (22 x 22 x 22 in.), with a hopper-shaped base and a tightly sealed, hinged lid shall be used. A blower is connected to the bottom of the hopper and is capable of delivering  $\sim 2.8 \text{ m}^3/\text{min}$  at a pressure of 2,250 Pa. A suitable agitator capable of inducing swirling in the air stream from the blower should be placed immediately above the air inlet. The dust chamber is equipped with an upper outlet that is connected to the blower inlet for recircula-

tion. The chamber is fitted with bars to support a headform, with the spacing of the bars sufficient to allow free circulation of the dust within the chamber.

Test dust,  $1000 \pm 50 \text{ g}$  of pulverized coal, shall be placed in the chamber. The coal dust shall have the following particle size distribution:

| Nominal sieve mesh dimension, mm | Minimum % passed through sieve |
|----------------------------------|--------------------------------|
| 0.300                            | 95%                            |
| 0.150                            | 85%                            |
| 0.090                            | 40%                            |
| 0.040                            | 3%                             |

The detection/test area on the headform shall be defined by white blotting paper of sufficient size to cover the lens area and extend at least 20 mm (0.79 in.) beyond the periphery of the protector to be tested and marked with two circles of 40 mm (1.57 in.) diameter centered over the pupillary center. If smaller sized protectors with the "H" designation are to be tested, the smaller headform shall be used and the blotting paper is to be marked with two circles of 40 mm (1.57 in.) diameter centered the pupillary center.

Absorbent cotton lint (surgical dressing), mass per unit area  $\sim 185 \text{ g/m}^2$  (0.26 sq. in.) is used to fit the protector more securely against the headform.

The test measurement device shall be a photoelectric reflectometer, incorporating a light source radiating energy within the visible range and a detector sensitive only to the visible range, with peak sensitivity in the green region.

A white comparison sample, capable of constant reflectance during the duration of the test (e.g., opal glass, ceramic tile, pressed barium sulfate, magnesium carbonate block, several thicknesses of clean white paper, etc.) shall be used as a test reference.

### 9.18.3 Procedure

Soak the blotting paper in water, and then shake off any excess. Using the reflectometer, measure the reflectance of each of the two circles on the wet blotting paper and on the white comparison

sample. Calculate the starting mean reflectance value of the two circles, relative to the value of the white reference.

Cover the headform with layers of absorbent cotton lint. Place the sheet of moist white blotting paper over the lint, with the marked circles centered over the eyes of the headform. Mount the protector on the headform. Adjust the headband to a normal degree of tension. Adjust the number of layers of lint, as necessary, to ensure a good seal between the protector and the headform.

Place the headform in the dust chamber, close the chamber, and operate the blower for  $60 \pm 2$  seconds. Allow the dust chamber to remain undisturbed for  $30 \pm 2$  minutes, then remove the headform. Carefully remove the blotting paper from the headform, ensuring that no additional dust is deposited on the areas of the circles.

Within 2 minutes of removal, re-measure the reflectance of the two circles relative to the white comparison sample. Calculate the final mean reflectance value. One complete device shall be tested.

## 9.19 Fine Dust Particle Test

### 9.19.1 Purpose

This test is intended to determine the capability of the protector to keep fine dust particles from reaching the wearer's eyes. This is not intended to evaluate the fit of the protector to the wearer's face. (See Annex K.11)

### 9.19.2 Apparatus

An enclosed gas-tight chamber with glass front and nominal dimensions of 56 x 56 x 56 cm (22 x 22 x 22 in.) shall be used. The gas chamber shall be ventilated by means of a blower capable of delivering  $\sim 1.4 \text{ m}^3/\text{min}$  and equipped with a vent pipe leading to a suitable gas removal/treatment system.

The detection/test area on the headform shall be defined by white blotting paper of sufficient size to cover the lens area and extend at least 20 mm (0.79 in.) beyond the periphery of the protector to be tested and marked with two circles of 40 mm (1.57 in.) diameter centered over the pupillary

center. If smaller sized protectors with the "H" designation are to be tested, the smaller headform shall be used and the blotting paper is to be marked with two circles of 40 mm (1.57 in.) diameter centered over the pupillary center. Absorbent cotton lint (surgical dressing), mass per unit area  $\sim 185 \text{ g/m}^2$  (0.26 sq. in.) is used to fit the protector more securely against the headform.

For the test, a supply of ammonia gas is connected to the gas chamber. Suitable supplies include ammonia gas cylinders, or bubbling air through a wash bottle containing a concentrated ( $\sim 0.9\text{g/ml}$  water) solution of ammonia. The detection solution shall be prepared by dissolving  $5.0 \pm 0.5 \text{ g}$  ( $0.18 \pm 0.018 \text{ oz.}$ ) phenolphthalein in  $500 \pm 50 \text{ ml}$  ( $16.9 \pm 1.69 \text{ fl oz.}$ ) ethanol and adding  $500 \pm 50 \text{ ml}$  ( $16.9 \pm 1.69 \text{ fl oz.}$ ) water, stirring constantly (filter if precipitate forms) to obtain  $1.0 \pm 0.1 \text{ L}$  ( $33.8 \pm 0.34 \text{ fl oz.}$ ) of solution.

### 9.19.3 Procedure

Cover the headform with several layers of absorbent cotton lint. Dip the white blotting paper into the detecting solution, shaking off any excess. Mount the moist paper over the lint, and then mount the protector on the headform. Adjust the headband to a normal degree of tension. Adjust the number of layers of lint, as necessary, to ensure a good seal between the protector and the headform.

Place a separate test strip of blotting paper dipped in detection solution on the floor of the chamber. Place the headform in the chamber. Open the chamber vent very slightly, then slowly introduce ammonia gas to fill the chamber. When the test strip changes to a crimson color, close the vent and leave the headform in the closed chamber for  $5.0 \pm 0.2 \text{ min.}$

At the end of this time, evacuate the chamber thoroughly by operating the blower. After the chamber has cleared of ammonia, remove the headform. Examine the test paper for coloration. One complete device shall be tested.

## 9.20 Anti-Fog Lens Test

### 9.20.1 Purpose

This test is intended to determine the ability of a lens component of a protector to resist fogging.

NOTE: This procedure does not assess resistance to fogging of the complete device.

### 9.20.2 Apparatus

Apparatus, to determine the change in the non-diffused transmittance value, as shown in Figure E9

The nominal diameter of the parallel beam is 10 mm (0.39 in.). The size of the beam divider, reflector R and lens L3 shall be selected in such a way that diffused light is captured up to an angle of 75°. If a lens L3 with a nominal focal length  $f_3 = 400$  mm (15.75 in.) is used, the nominal diameter of a diaphragm is 10 mm (0.39 in.). The plane of the diaphragm must lie within the focal plane of the lens L3.

The following focal lengths  $f_i$  of the lenses  $L_i$  are nominal examples and will not affect the test results:

$$f_1 = 10 \text{ mm (0.39 in.) and } f_2 = 100 \text{ mm (3.9 in.)}$$

The light source shall be a laser with a wavelength of  $600 \pm 70$  nm.

The volume of air above the water bath is at least 4 l. The seating ring has a nominal diameter of 35 mm (1.38 in.) and a nominal height of 24 mm (0.94 in.) from the underside of the lid of the water bath. If the samples are cylindrically curved, the curve on the top side of the seating ring is to be adjusted to fit the curve of the sample. The height of 24 mm (0.94 in.) is then measured to the highest point of the seating ring. A soft rubber ring, with a nominal dimension of 3 mm (0.11 in.) thick and 3 mm (0.11 in.) wide, is inserted between the sample and the seating ring.

The water bath container also contains a ventilator to circulate the air. In addition, there must also be a device to stabilize the temperature of the water bath.

### 9.20.3 Samples

Before the test, the samples are conditioned for between one and two hours in distilled water (at least 5 cm<sup>3</sup> water per cm<sup>2</sup> sample surface area) at  $23 \pm 5$  °C ( $73 \pm 9$ °F), then dabbed dry and then conditioned in air for at least 12 to 24 hours at  $23 \pm 5$  °C ( $73 \pm 9$ °F) and 50 % nominal relative humidity.

### 9.20.4 Procedure and Evaluation

The temperature of the water bath is set at  $50 \pm 0.5$  °C ( $122 \pm 0.9$  °F). The air above the water bath is circulated using a ventilator, so that it becomes saturated with water vapor. During this time, the measurement opening is to be covered. The ventilator is switched off before measurement. The sample must be placed in the test position within 2 seconds of the opening being uncovered.

To measure the change in the value of the transmittance  $\tau_r$  the sample is placed on the seating ring and the time determined until the square of  $\tau_r$  has dropped to less than 80 % of the initial value of the sample without fogging (time without fogging).

$$\tau_r^2 = \frac{\Phi_b}{\Phi_u}$$

where

$\Phi_b$  is the luminous flux when there is fogging on the sample;

$\Phi_u$  is the luminous flux before fogging.

Initial fogging of maximum 0.5 second duration shall not be taken into consideration in the evaluation.

NOTE 1: Since the light beam passes through the sample twice, this measurement defines  $\tau_r^2$ .

NOTE 2: The period until the start of the fogging can usually be determined visually. However, with some types of coating the formation of surface water causes diffusion to increase more slowly so that visual evaluation is difficult. The detection apparatus described in Section 9.20.2 should then be used.

Four (4) representative lenses for each type of protector shall be tested.

and disinfected prior to use by another person, following the manufacturer's instructions.

## **10. Instructions, Use and Maintenance**

### **10.1 General**

Eye and face protection shall be required where there is a reasonable probability of injury that can be prevented by such equipment. In such cases, employers and educational authorities shall make conveniently available a protector for the work environment, per applicable federal and state regulations. Employees and students shall use such protectors.

Annex J contains a selection guide, which will be helpful in deciding types of protectors that are available, their capabilities and limitations. It should be recognized that dusty or chemical environments or both might represent an additional hazard to contact lens wearers. Wearers of contact lenses shall be required to wear appropriate eye and face protectors in a hazardous environment.

### **10.2 Instructions**

Employers and educational authorities shall provide employees and students with all warnings, cautions, instructions and limitations provided with the protector by the manufacturer and inform wearers as to their meaning.

### **10.3 Inspections**

Employees and students shall make a visual inspection of their protector prior to each use. Protectors which exhibit broken parts, distortion, or excessive scratches on the lens, are unsuitable for use and shall not be worn. Eye and face protectors that have been subject to an impact shall not be used and shall be discarded and replaced.

### **10.4 Maintenance and Care**

Protectors shall be maintained in a usable condition in accordance with the manufacturer's instructions. Reasonable care shall be taken during the use and storage of protectors so that they are not subject to unnecessary abuse.

When one protector is being used by more than one person, it is recommended that it be cleaned

### **10.5 Training**

Employers and educational authorities shall train employees and students in the proper use, application, inspection, maintenance, storage, fitting and limitations of eye and face protectors.

**Annex A: Samples for Testing**  
(normative)

| <b>REQUIRED FOR ALL PROTECTORS</b> |   |                             |
|------------------------------------|---|-----------------------------|
| <b>Reference Section</b>           | <b>Test Attribute</b>   | <b>Quantity for Testing</b> |
| 5.1.5                              | Refractive Power, Astigmatism, Prism and Prism Imbalance (Rx)         | 100% testing                |
| 5.1.5                              | Refractive Power, Astigmatism, Prism and Prism Imbalance (magnifiers) | 1 per power                 |
| 5.2.4                              | Minimum Coverage Area   | 1                           |
| 9.1                                | Optical Quality   | 1                           |
| 9.2                                | Transmittance   | 1                           |
| 9.3                                | Haze  | 1                           |
| 9.4                                | Refractive Power, Astigmatism, and Resolving Power (plano and reader) | 1                           |
| 9.5                                | Prismatic Power (plano and reader)                                    | 1                           |
| 9.6                                | Drop Ball   | 4                           |
| 9.7                                | Ignition  | 1                           |
| 9.8                                | Corrosion Resistance  | 1                           |
| 9.9                                | Light Tightness   | 1                           |

| <b>TESTING REQUIRED ONLY WHEN CLAIMS OF COMPLIANCE ARE MADE</b> |   |                             |
|---|---|-----------------------------|
| <b>Reference Section</b>  | <b>Test Attribute</b>   | <b>Quantity for Testing</b> |
| 9.10  | Lateral Protection  | 1                           |
| 9.11  | High-Mass Impact (plano, Rx, readers, magnifiers, Rx lens carriers)                   | 4                           |
| 9.12  | High-Velocity Impact (plano, Rx, readers, magnifiers)                                 | 6                           |
| 9.12  | High-Velocity Impact (Rx lens carriers)   | 12                          |
| 9.13  | Penetration   | 4                           |
| 9.14  | Prescription Lenses Material  | 3                           |
| 9.15  | Switching Index   | 1                           |
| 9.16  | Angular Dependence of Luminous Transmittance Test for Automatic Welding Filter Lenses | 1                           |
| 9.17  | Droplet and Splash  | 1                           |
| 9.18  | Dust  | 1                           |
| 9.19  | Fine Dust Particle  | 1                           |
| 9.20  | Anti-Fog Lens Test  | 4                           |

## **Annex B: Reference Headforms** (normative)

NOTE: Permission to reproduce extracts from EN 168:2001 *Personal eye-protection. Non-optical test methods* are granted by BSI on behalf of CEN. Copyright subsists in all CEN Standards.

### **Headform Description**

There are two sizes of reference head-form for the non-optical tests described in ANSI/ISEA Z87.1-2020.

The medium head-form approximates a 50<sup>th</sup> percentile adult male. The small head-form approximates a 60<sup>th</sup> percentile, 12-year-old child.

The nominal dimensions are shown in Figure B1.

Where reference is made in this standard to a headform specified in this clause, the size of headform (medium or small) to be used shall be that which is appropriate to the eye protector being assessed.

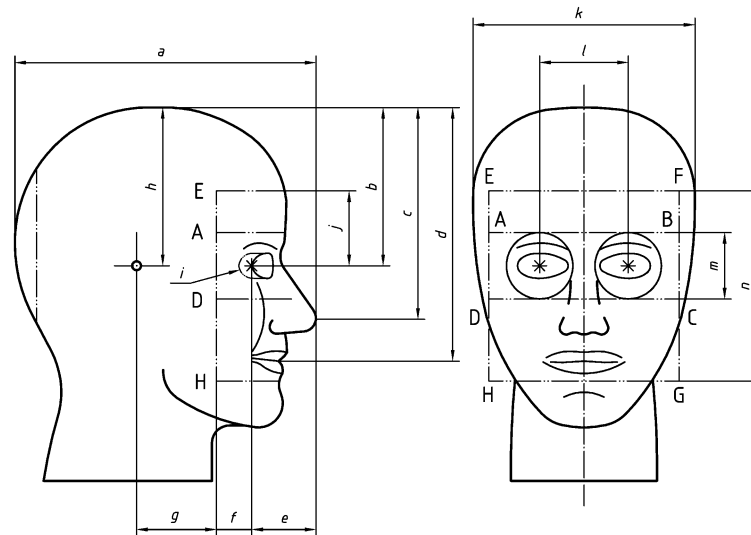
Unless otherwise specified by the manufacturer of the eye protector, the medium size head-form shall be used.

All tests on the eye protector shall be performed using only the one size of headform selected.

The headform is an internal core covered by a nominal 12 mm thick layer of polyurethane of hardness (50 ± 5) IRHD.

Other headforms may be used if known or demonstrated to give equivalent results.





**Figure B1 – Reference Head form**

| Dimension | Value            |                  |
|-----------|------------------|------------------|
|           | Medium size head | Small size head  |
| a         | 218 mm (8.6 in.) | 205 mm (8.1 in.) |
| b         | 111 mm (4.4 in.) | 110 mm (4.3 in.) |
| c         | 144 mm (5.7 in.) | 131 mm (5.2 in.) |
| d         | 178 mm (7.0 in.) | 166 mm (6.5 in.) |
| e         | 45 mm (1.8 in.)  | 42 mm (1.7 in.)  |
| f         | 18 mm (0.7 in.)  | 18 mm (0.7 in.)  |
| g         | 60 mm (2.4 in.)  | 53 mm (2.1 in.)  |
| h         | 111 mm (4.4 in.) | 110 mm (4.3 in.) |
| Radius i  | 10 mm (0.4 in.)  | 10 mm (0.4 in.)  |
| j         | 58 mm (2.0 in.)  | 48 mm (1.9 in.)  |
| k         | 156 mm (6.1 in.) | 146 mm (5.7 in.) |
| l         | 64 mm (2.5 in.)  | 54 mm (2.1 in.)  |
| m         | 52 mm (2.0 in.)  | 48 mm (1.9 in.)  |
| n         | 134 mm (5.3 in.) | 118 mm (4.6 in.) |

NOTE: The metric measurements take precedent. The U.S. measurement are included as an approximation for reference only.

**Annex C: Spectral Factor Tables**  
(normative)

| <b>Table C1. Relative Weighting Factors <math>S(\lambda)</math> for Effective Far-Ultraviolet Average Transmittance</b> |  |
|---|--|
| <b>Wavelength<br/>(nm)</b>  | <b>Spectral Weighting Factor <math>W(\lambda)</math></b> |
| 200   | 0.03   |
| 210   | 0.075  |
| 220   | 0.12   |
| 230   | 0.19   |
| 240   | 0.30   |
| 250   | 0.43   |
| 254   | 0.5  |
| 260   | 0.65   |
| 270   | 1.0  |
| 280   | 0.88   |
| 290   | 0.64   |
| 300   | 0.30   |
| 305   | 0.06   |
| 310   | 0.015  |
| 315   | 0.003  |

NOTE: This table is a reproduction of Table 1 “Ultraviolet Radiation TLV and Relative Spectral Effectiveness,” from *Threshold Limit Values for Chemical Substances and Physical Agents & Biological Exposure Indices for 2017*. Published by the American Conference of Governmental Industrial Hygienists.

**Table C2. Values of Relative Luminous Efficiency  $\bar{y}(\lambda)$  for the CIE 1931 Standard colorimetric Observer and of Relative Spectral Emittance  $S_A(\lambda)$  For CIE Illuminant A**

| $\lambda(\text{nm})$ | $\bar{y}(\lambda)$ | $S(\lambda)$ | $\lambda(\text{nm})$ | $\bar{y}(\lambda)$ | $S(\lambda)$ |
|----------------------|--------------------|--------------|----------------------|--------------------|--------------|
| 380                  | 0.0000             | 9.80         | 575                  | 0.9154             | 110.80       |
| 385                  | 0.0001             | 10.90        | 580                  | 0.8700             | 114.44       |
| 390                  | 0.0001             | 12.09        | 585                  | 0.8163             | 118.08       |
| 395                  | 0.0002             | 13.35        | 590                  | 0.7570             | 121.73       |
|                      |                    |              | 595                  | 0.6949             | 125.39       |
| 400                  | 0.0004             | 14.71        |                      |                    |              |
| 405                  | 0.0006             | 16.15        | 600                  | 0.6310             | 129.04       |
| 410                  | 0.0012             | 17.68        | 605                  | 0.5668             | 132.70       |
| 415                  | 0.0022             | 19.29        | 610                  | 0.5030             | 136.35       |
| 420                  | 0.0040             | 20.99        | 615                  | 0.4412             | 139.99       |
|                      |                    |              | 620                  | 0.3810             | 143.62       |
| 425                  | 0.0073             | 22.79        |                      |                    |              |
| 430                  | 0.0116             | 24.67        | 625                  | 0.3210             | 147.24       |
| 435                  | 0.0168             | 26.64        | 630                  | 0.2650             | 150.84       |
| 440                  | 0.0230             | 28.70        | 635                  | 0.2170             | 154.42       |
| 445                  | 0.0298             | 30.85        | 640                  | 0.1750             | 157.98       |
|                      |                    |              | 645                  | 0.1382             | 161.52       |
| 450                  | 0.0380             | 33.09        |                      |                    |              |
| 455                  | 0.0480             | 35.41        | 650                  | 0.1070             | 165.03       |
| 460                  | 0.0600             | 37.81        | 655                  | 0.0816             | 168.51       |
| 465                  | 0.0739             | 40.30        | 660                  | 0.0610             | 171.96       |
| 470                  | 0.0910             | 42.87        | 665                  | 0.0446             | 175.38       |
|                      |                    |              | 670                  | 0.0320             | 178.77       |
| 475                  | 0.1126             | 45.52        |                      |                    |              |
| 480                  | 0.1390             | 48.24        | 675                  | 0.0232             | 182.12       |
| 485                  | 0.1693             | 51.04        | 680                  | 0.0170             | 185.43       |
| 490                  | 0.2080             | 53.91        | 685                  | 0.0119             | 188.70       |
| 495                  | 0.2586             | 56.85        | 690                  | 0.0082             | 191.93       |
|                      |                    |              | 695                  | 0.0057             | 195.12       |
| 500                  | 0.3230             | 59.86        |                      |                    |              |
| 505                  | 0.4073             | 62.93        | 700                  | 0.0041             | 198.26       |
| 510                  | 0.5030             | 66.06        | 705                  | 0.0029             | 201.36       |
| 515                  | 0.6082             | 69.25        | 710                  | 0.0021             | 204.41       |
| 520                  | 0.7100             | 72.50        | 715                  | 0.0015             | 207.41       |
|                      |                    |              | 720                  | 0.0010             | 210.36       |
| 525                  | 0.7932             | 75.79        |                      |                    |              |
| 530                  | 0.8620             | 79.13        | 725                  | 0.0007             | 213.27       |
| 535                  | 0.9149             | 82.52        | 730                  | 0.0005             | 216.12       |
| 540                  | 0.9540             | 85.95        | 735                  | 0.0004             | 218.92       |
| 545                  | 0.9803             | 89.41        | 740                  | 0.0002             | 221.67       |
|                      |                    |              | 745                  | 0.0002             | 224.36       |
| 550                  | 0.9950             | 92.91        |                      |                    |              |
| 555                  | 1.0000             | 96.44        | 750                  | 0.0001             | 227.00       |
| 560                  | 0.9950             | 100.00       | 755                  | 0.0001             | 229.59       |
| 565                  | 0.9786             | 103.58       | 760                  | 0.0001             | 232.12       |
| 570                  | 0.9520             | 107.18       | 765                  | 0                  | 234.59       |
|                      |                    |              |                      |                    |              |
|                      |                    |              | 770                  | 0                  | 237.01       |
|                      |                    |              | 775                  | 0                  | 239.37       |
|                      |                    |              | 780                  | 0                  | 241.68       |

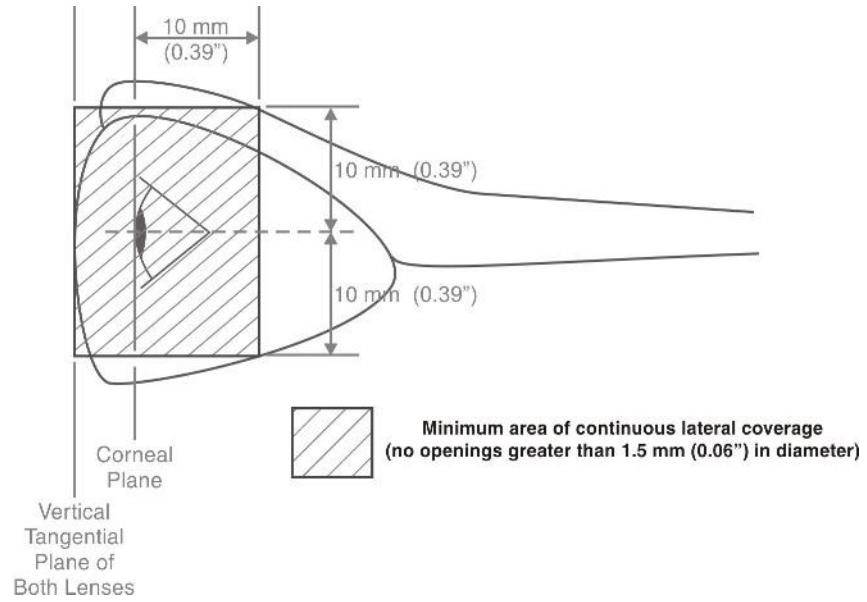
**Table C3. Relative Spectral Emittance  $S_A(\lambda)$  of CIE Illuminant A  
for Wavelengths from 700 nm to 2600 nm**

| $\lambda$ | $S(\lambda)$ | $\lambda$ | $S(\lambda)$ | $\lambda$ | $S(\lambda)$ | $\lambda$ | $S(\lambda)$ | $\lambda$ | $S(\lambda)$ | $\lambda$  | $S(\lambda)$ |
|-----------|--------------|-----------|--------------|-----------|--------------|-----------|--------------|-----------|--------------|--|--------------|
| 700       | 198.26       | 1050      | 298.78       | 1400      | 232.72       | 1750      | 161.42       | 2100      | 108.81       | 2450   | 73.94        |
| 710       | 204.41       | 1060      | 289.28       | 1410      | 230.56       | 1760      | 159.63       | 2110      | 107.60       | 2460   | 73.15        |
| 720       | 210.36       | 1070      | 288.66       | 1420      | 228.40       | 1770      | 157.86       | 2120      | 106.40       | 2470   | 72.37        |
| 730       | 216.12       | 1080      | 287.94       | 1430      | 226.23       | 1780      | 156.10       | 2130      | 105.21       | 2480   | 71.60        |
| 740       | 221.67       | 1090      | 287.12       | 1440      | 224.06       | 1790      | 154.37       | 2140      | 104.04       | 2490   | 70.83        |
| 750       | 227.00       | 1100      | 286.20       | 1450      | 221.90       | 1800      | 152.65       | 2150      | 102.88       | 2500   | 70.08        |
| 760       | 232.12       | 1110      | 285.18       | 1460      | 219.74       | 1810      | 150.94       | 2160      | 101.73       | 2510   | 69.33        |
| 770       | 237.01       | 1120      | 284.08       | 1470      | 217.58       | 1820      | 149.25       | 2170      | 100.60       | 2520   | 68.60        |
| 780       | 241.68       | 1130      | 282.90       | 1480      | 215.42       | 1830      | 147.59       | 2180      | 99.48        | 2530   | 67.87        |
| 790       | 246.12       | 1140      | 281.64       | 1490      | 213.27       | 1840      | 145.93       | 2190      | 98.38        | 2540   | 67.15        |
| 800       | 250.83       | 1150      | 280.30       | 1500      | 211.13       | 1850      | 144.30       | 2200      | 97.29        | 2550   | 66.44        |
| 810       | 254.31       | 1160      | 278.89       | 1510      | 209.00       | 1860      | 142.68       | 2210      | 96.21        | 2560   | 65.74        |
| 820       | 258.07       | 1170      | 277.42       | 1520      | 206.87       | 1870      | 141.08       | 2220      | 95.14        | 2570   | 65.05        |
| 830       | 261.60       | 1180      | 275.89       | 1530      | 204.75       | 1880      | 139.50       | 2230      | 94.09        | 2580   | 64.37        |
| 840       | 264.91       | 1190      | 274.29       | 1540      | 202.64       | 1890      | 137.93       | 2240      | 93.05        | 2590   | 63.69        |
| 850       | 267.99       | 1200      | 272.64       | 1550      | 200.54       | 1900      | 136.38       | 2250      | 92.03        | 2600   | 63.02        |
| 860       | 270.86       | 1210      | 270.94       | 1560      | 198.45       | 1910      | 134.85       | 2260      | 91.01        |  |              |
| 870       | 273.51       | 1220      | 269.20       | 1570      | 196.38       | 1920      | 133.33       | 2270      | 90.01        |  |              |
| 880       | 275.95       | 1230      | 267.40       | 1580      | 194.31       | 1930      | 131.83       | 2280      | 89.02        |  |              |
| 890       | 278.18       | 1240      | 265.57       | 1590      | 192.26       | 1940      | 130.35       | 2290      | 88.05        |  |              |
| 900       | 280.21       | 1250      | 263.70       | 1600      | 190.22       | 1950      | 128.89       | 2300      | 87.08        | Calculate by method given in Publication CIE No.15 (E-1.3.1) 1971 "COLORIMETRY," p. 23, par. (b) |              |
| 910       | 282.04       | 1260      | 261.79       | 1610      | 188.19       | 1960      | 127.44       | 2310      | 86.13        |  |              |
| 920       | 283.68       | 1270      | 259.83       | 1620      | 186.18       | 1970      | 126.00       | 2320      | 85.19        |  |              |
| 930       | 285.12       | 1280      | 257.88       | 1630      | 184.18       | 1980      | 124.59       | 2330      | 84.26        |  |              |
| 940       | 286.39       | 1290      | 255.88       | 1640      | 182.20       | 1990      | 123.19       | 2340      | 83.34        |  |              |
| 950       | 287.47       | 1300      | 253.86       | 1650      | 180.23       | 2000      | 121.80       | 2350      | 82.43        | Values start at 700 nm to show overlap with values in Table C2 of this appendix.                 |              |
| 960       | 288.39       | 1310      | 251.81       | 1660      | 178.28       | 2010      | 120.43       | 2360      | 81.53        |  |              |
| 970       | 289.14       | 1320      | 249.74       | 1670      | 176.34       | 2020      | 119.08       | 2370      | 80.65        |  |              |
| 980       | 289.72       | 1330      | 247.66       | 1680      | 174.42       | 2030      | 117.74       | 2380      | 79.77        |  |              |
| 990       | 290.15       | 1340      | 245.56       | 1690      | 172.51       | 2040      | 116.42       | 2390      | 78.91        |  |              |
| 1000      | 290.43       | 1350      | 243.45       | 1700      | 170.62       | 2050      | 115.12       | 2400      | 78.06        |  |              |
| 1010      | 290.57       | 1360      | 241.32       | 1710      | 168.75       | 2060      | 113.83       | 2410      | 77.21        |  |              |
| 1020      | 290.57       | 1370      | 239.18       | 1720      | 166.89       | 2070      | 112.55       | 2420      | 76.38        |  |              |
| 1030      | 290.43       | 1380      | 237.04       | 1730      | 165.05       | 2080      | 111.29       | 2430      | 75.56        |  |              |
| 1040      | 290.17       | 1390      | 234.88       | 1740      | 163.23       | 2090      | 110.04       | 2440      | 74.75        |  |              |

| <b>Table C4. Spectral Weighting Factors<br/>For Blue-Light Hazard</b> |  |
|---|--|
| <b>Wavelength<br/>(nm)</b>  | <b>Blue-Light hazard<br/>Factors B(<math>\lambda</math>)</b> |
| 400   | .10  |
| 405   | .20  |
| 410   | .40  |
| 415   | .80  |
| 420   | .90  |
| 425   | .95  |
| 430   | .98  |
| 435   | 1.00   |
| 440   | 1.00   |
| 445   | .97  |
| 450   | .94  |
| 455   | .90  |
| 460   | .80  |
| 465   | .70  |
| 470   | .62  |
| 475   | .55  |
| 480   | .45  |
| 485   | .40  |
| 490   | .22  |
| 495   | .16  |
| 500-600   | $10 \exp [(450-\lambda)/50]$                                 |
| 600-700   | .001   |

NOTE: This table is a reproduction of part of Table 1 “Retinal and UVR Hazard Spectral Weighting Functions”, from *Threshold Limit Values for Chemical Substances and Physical Agents & Biological Exposure Indices for 2017*. Published by the American Conference of Governmental Industrial Hygiene.

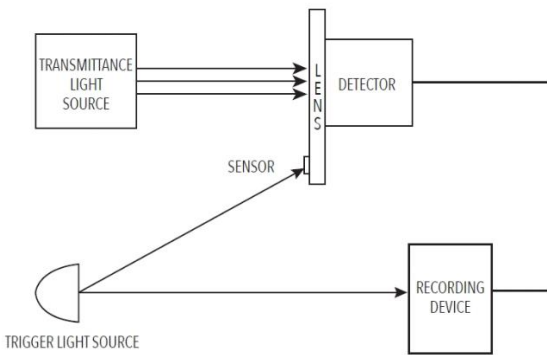
**Annex D. Lateral (Side) Coverage Illustration (for Medium Headform)**  
(informative)



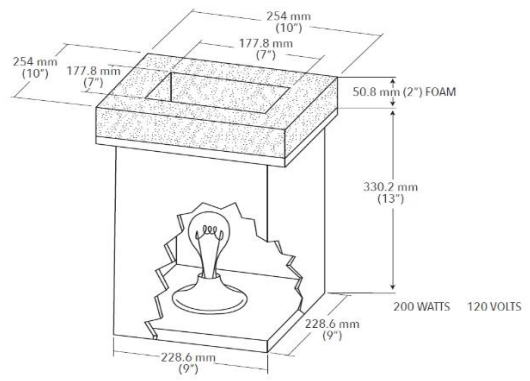
**Annex E. Test Apparatus**  
(informative)



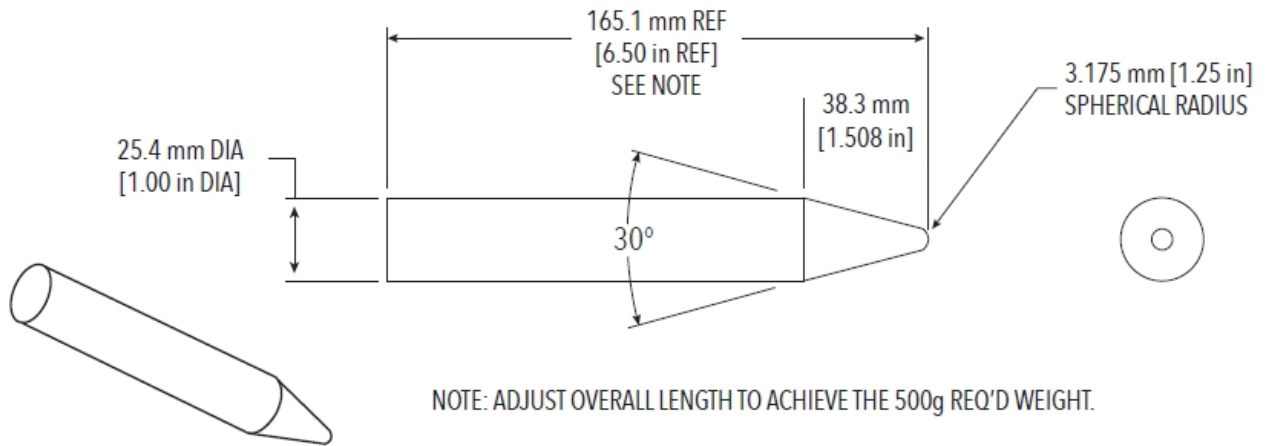
**Figure E1 - High Velocity Impact Test Apparatus**  
The unit shown above or its equivalent is suitable for the high velocity impact test



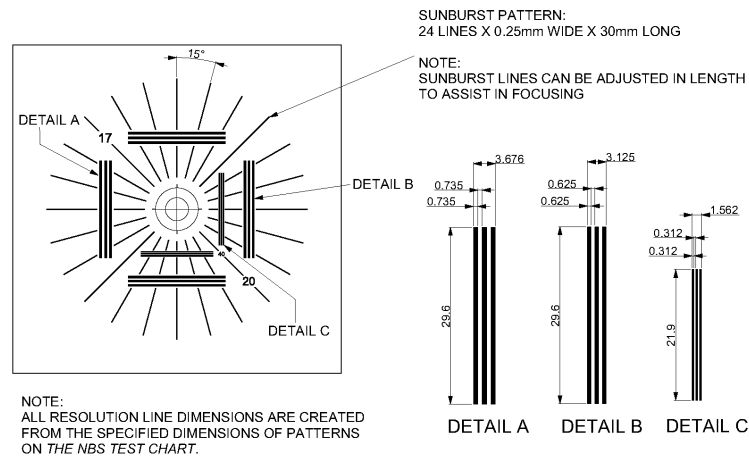
**Figure E2**  
**Switching Index Tightness Test Apparatus**



**Figure E3**  
**Typical Light Test Set Up Configuration**

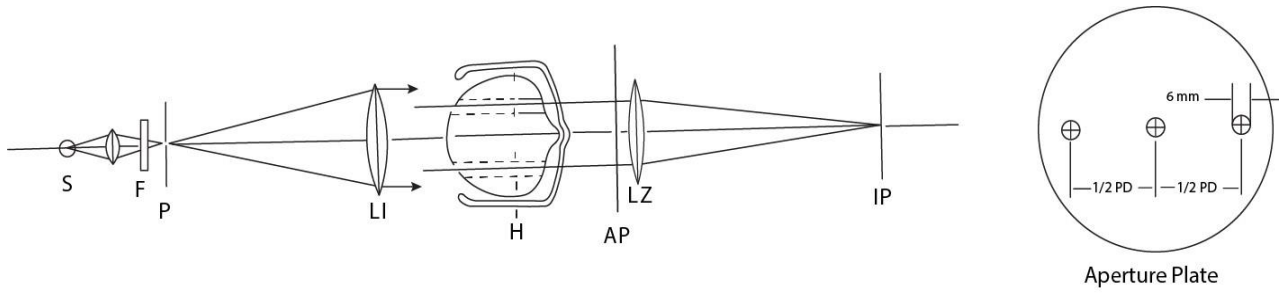


**Figure E4**  
**High Mass Impact Missile**



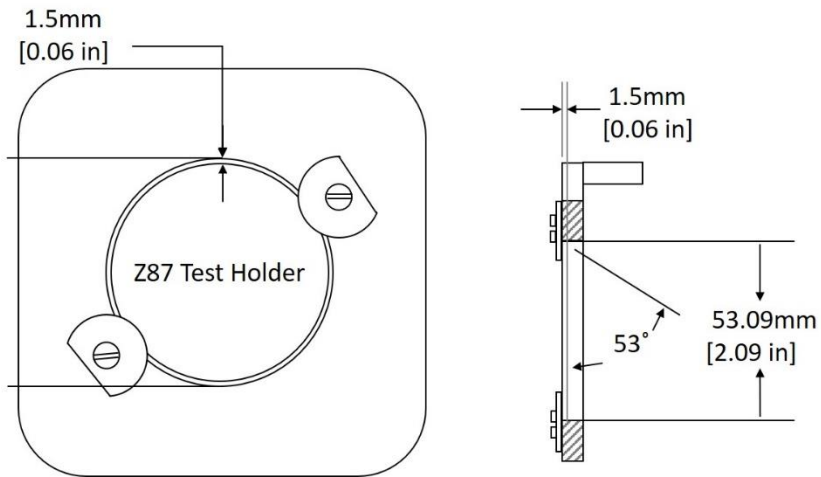
**Figure E5**  
**Test Resolution Pattern with Radial Sunburst Power Target Superimposed**



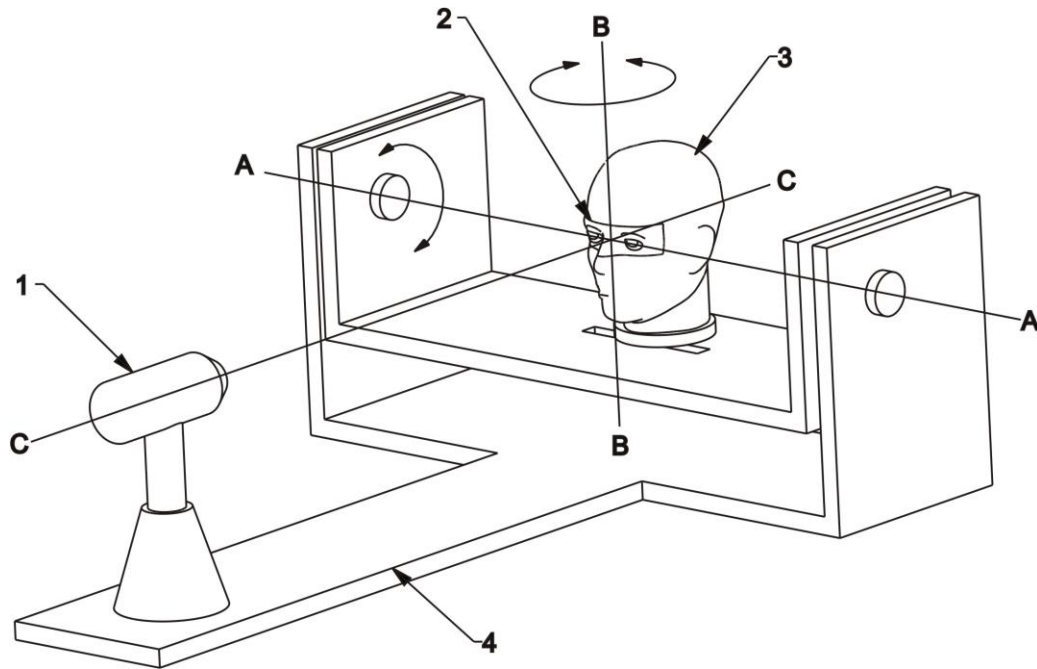


- S Small Tungsten Light Source
- F Interference Filter, Maximum Transmission at 590 +/- 20 nanometers
- P Pinhole Aperture, Plate with 0.5mm (0.02in.) diameter hole
- L1 Collimator Lens, fl = 1m (39.4in)
- H Headform (19mm diameter through holes through both eyes)
- AP Aperture Plate
- L2 Telescope Lens, fl = 1m (39.4in.)
- IP Image Plane with Diffuser and Rectangular Grid Pattern

**Figure E6 Prism Imbalance Test Apparatus**



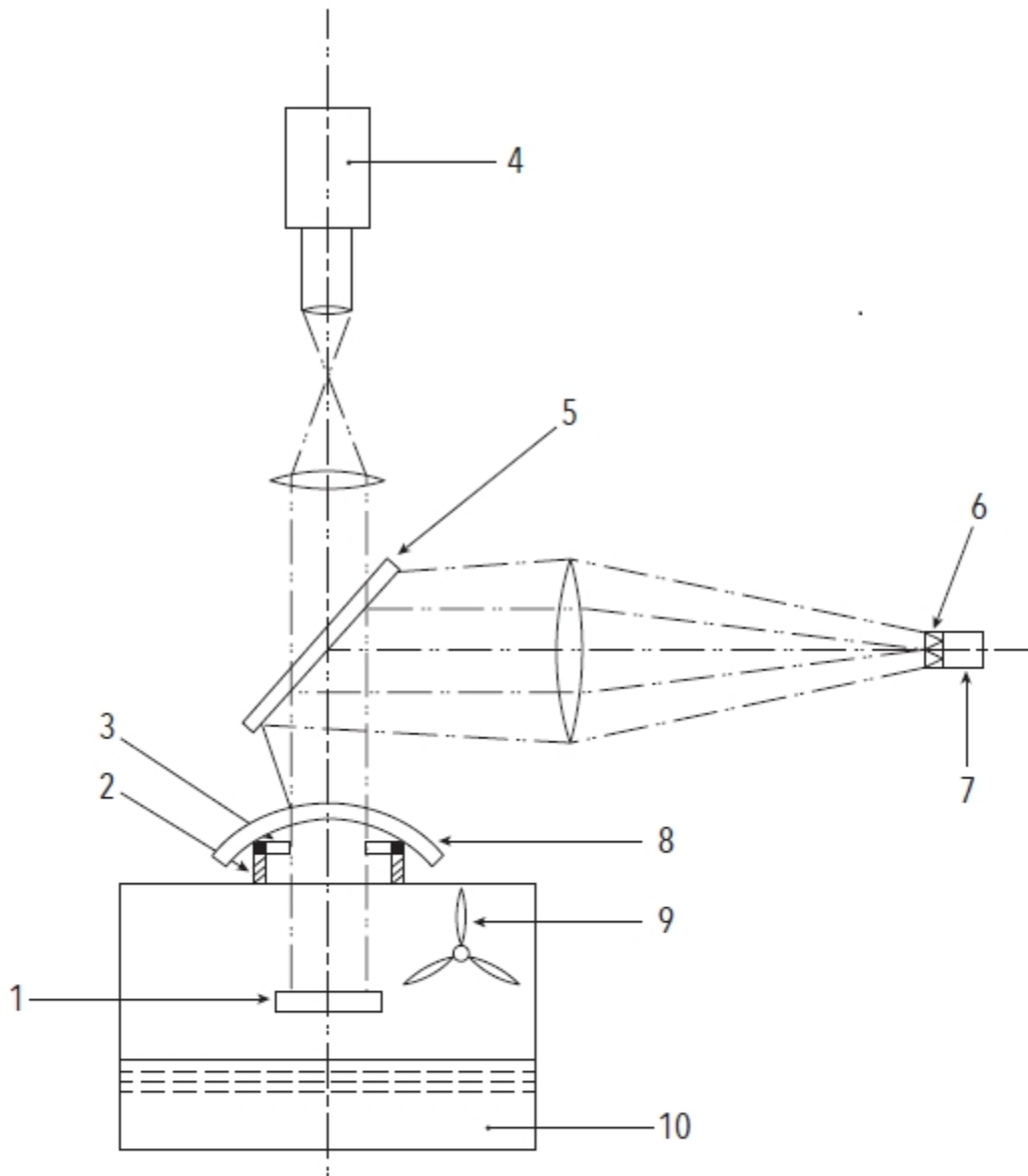
**Figure E7 Prescription Lens Test Holder**



## Key

- 1 laser beam or cylindrical tube fitted with cross wires
- 2 rectangle enclosing the eye region
- 3 headform
- 4 support frame

**Figure E8. Droplet and Splash Test Set Up for Faceshields**



### Key

|   |                  |    |            |
|---|------------------|----|------------|
| 1 | Mirror           | 6  | Diaphragm  |
| 2 | Seating ring     | 7  | Receptor   |
| 3 | Soft rubber ring | 8  | Sample     |
| 4 | Laser            | 9  | Ventilator |
| 5 | Beam divider     | 10 | Water bath |

**Figure E9. Anti-Fog Lens Test Set Up**

## Annex F: Calibration of Test Telescope (informative)

The telescope may be calibrated by any of the three methods given below.

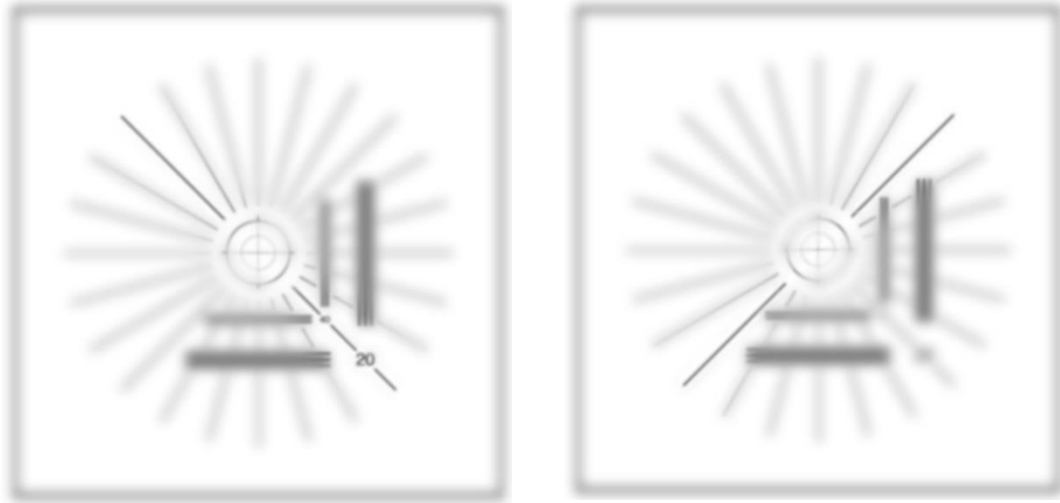
(1) The telescope may be calibrated by successively locating the position of best focus with first a standard lens of +0.06 D in front of the objective and then with a standard lens of -0.06 D in front of the objective. The positions of the telescope drawtube or focusing knob, which correspond to the +/-0.06 D positions are marked on a suitable scale. The zero power position is located half the distance between the two marks. It should be verified that with no lens in front of the test telescope, the position of sharpest focus of the target is at the zero power scale position determined above. It is suggested that the scale distance between the +0.06 D position and -0.06 D position be divided into at least twenty equally spaced intervals so as to allow reasonably accurate determination of astigmatism.

(2) If effective focal length,  $f$ , of the telescope objective is measured or is known from data furnished with the telescope, then calibration of the power scale of the telescope may be done as follows:

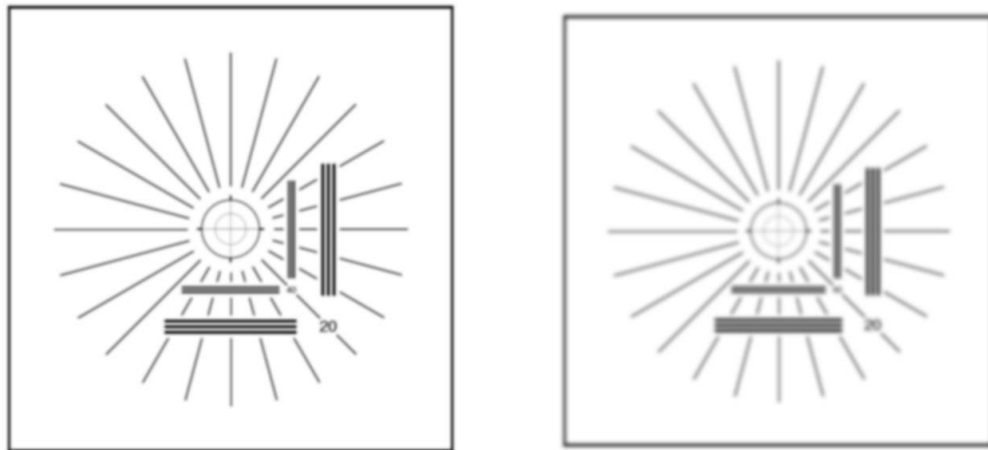
Since  $P$ , the power of the telescope objective, is the reciprocal of the effective focal length of the objective in meters, if a lens of lower power, such as a plano lens, is placed near the telescope objective, the combined system will have a small change in focal length which causes re-focusing of the telescope to be necessary. Since  $P = 1/f$ , then  $dP = -df/f$  and hence  $df = -fdP$ . Since the focal length of a typical test telescope is in the order of 200 mm (7.9 in.) (and hence it has a power of 5 Ds), the change in focal position produced by putting an acceptable plano lens in front of a telescope is small and hence the change in focal length (change of eyepiece position for best focus) is proportional to the power of the plano lens placed in front of the objective. Having calculated, then, the scale span between the +0.06 D and -0.06 D positions, the zero position must be determined. This is best done by having several operators take a number of readings at the best focus position for the 10.67 m (35 ft) distant target when no lens is in front of the telescope objective, and then averaging those readings. Before taking the readings, each operator should focus the eyepiece first on the cross hairs to suit his individual visual requirements.

(3) Vergence of light from a target at a distance of 10.67 m is  $1/10.67 = -0.09372$  D, so the vergence required of the telescope is +0.09372 D to form an image of the target when no test lens is in place. If a lens of +0.06 D is placed in front of the telescope, vergence of light reaching the telescope is  $-0.09372$  D + 0.06 D =  $-0.033721$  D, which corresponds to light from a target at  $1/0.033721$  D = 29.66 m (97.3 ft). Similarly, if a lens of -0.06 D is used, vergence of light reaching the telescope is  $-0.09372$  D - 0.06 D =  $-0.153721$  D, which corresponds to light from a target at 6.51 m (21.4 ft). Therefore, the positions of the telescope focusing knob corresponding to test lens powers of +/-0.06 D can be established by focusing the telescope at targets spaced 29.66 m (97.3 ft) and 6.51 m (21.4 ft) respectively from the telescope.

**Annex G. Illustrations to Aid in Refractive Power, Astigmatism and Resolving Power Testing**  
(informative)



**Figure G1: Example of Resolution**



**Figure G2: Examples of Resolution (Passing)**



**Figure G3: Example of Resolution (Failing)**

Note: The examples provided here are illustrations for educational purposes only and are not definitive examples of pass/fail.

**Annex H. Sources for Test Apparatus**  
(informative)

*For sources of test apparatus, headforms and test patterns, visit:  
[www.safetysafetyequipment.org](http://www.safetysafetyequipment.org)*

**Annex I. Resource Publications**  
(informative)

ANSI Z49.1-2012, *American National Standard Safety in Welding and Cutting*

ANSI/ISEA Z89.1-2014 (R2019) *American National Standard for Industrial Head Protection*

ANSI Z136.1-2014, *American National Standard for Safe Use of Lasers*

ASTM F803 – 14 *Standard Specification for Eye Protectors for Selected Sports*

NFPA 70E – 2018, *Standard for Electrical Safety in the Workplace*

29 CFR 1910.133 - *Eye and Face Protection, OSHA General Industry Standards*

29 CFR 1915.153 - *Eye and Face Protection, OSHA Shipyard Standards*

29 CFR 1926.102 - *Eye and Face Protection, OSHA Construction Industry Standards*

## Annex J. Eye and Face Selection Guide (informative)

### ANSI/ISEA Z87.1-2020

#### Eye and Face Protector Selection Guide

*This guide is not intended to be the sole reference in selecting the proper eye and face protector. A copy of this selection guide is also available for download from ISEA's website, [www.safetyequipment.org](http://www.safetyequipment.org).*

This information is intended to aid in identifying and selecting the types of eye and face protectors that are available, their capabilities and limitations for the hazards listed. Care should be taken to recognize the possibility of multiple and simultaneous hazard exposures and the chosen protector(s) should be able to protect against the highest level of each hazard. Some protectors may not be compatible with other personal protective equipment when worn together. The end user needs to carefully match protectors with other personal protective equipment to provide the protection intended. Protectors are generally available in a variety of styles and sizes and care should be taken to ensure that the right size is selected for a particular person ensuring comfort and proper fit. Protectors that fit poorly will not afford the protection for which they were designed.

| Hazard   | Protectors   | Limitations  | Marking <sup>1</sup>  |
|--|--|--|---|
| <b>IMPACT - Chipping, grinding, machining, masonry work, riveting, and sanding</b>         |  |  |   |
| <b>Flying fragments, objects, large chips, particles, sand, dirt, etc.</b>                 | <ul style="list-style-type: none"> <li>• Spectacles with side protection</li> <li>• Goggles with direct or indirect ventilation</li> <li>• Faceshield worn over spectacles or goggles</li> <li>• Welding helmet worn over spectacles or goggles</li> <li>• Loose-fitting respirator worn over spectacles or goggles</li> <li>• Full-facepiece respirators</li> </ul> | <p>Caution should be exercised in the use of metal frame protective devices in electrical hazard areas. Metal frame protective devices could potentially cause electrical shock and electrical burn through contact with, or thermal burns from exposure to the hazards of electrical energy, which include radiation from accidental arcs.</p> <p>To provide adequate protection, ensure goggles fit tightly to the face.</p> <p>Atmospheric conditions and the restricted ventilation of a protector can cause lenses to fog. Frequent cleaning may be required.</p> | Impact rated:<br>+ (spectacle lens)<br><b>Z87+</b> (all other lens)<br><b>Z87+</b> (plano frame)<br><b>Z87-2+</b> (Rx frame)                    |
| <b>HEAT - Furnace operations - pouring, casting, hot dipping, gas cutting, and welding</b> |  |  |   |
| <b>Hot sparks</b>  | <ul style="list-style-type: none"> <li>• Spectacles with side protection</li> <li>• Goggles with direct or indirect ventilation</li> <li>• Faceshield worn over spectacles or goggles</li> <li>• Loose-fitting respirator worn over spectacles</li> <li>• Full-facepiece respirator</li> </ul>   | <p>Spectacles, cup and cover type goggles do not provide unlimited facial protection.</p> <p>Operations involving heat may also involve optical radiation. Protection from both hazards shall be provided.</p>   | NOTE: There are currently no marking designations for eye protection to heat or high-temperature exposure in the ANSI/ISEA Z87.1-2020 standard. |
| <b>Splash from molten metal</b>  | <ul style="list-style-type: none"> <li>• Faceshield worn over goggles</li> <li>• Loose-fitting respirator worn over spectacles or goggles</li> <li>• Full-facepiece respirator</li> </ul>  |  |   |



| Hazard  | Protectors   | Limitations  | Marking <sup>1</sup>  |
|---|--|--|---|
| <b>High temperature exposure</b>  | <ul style="list-style-type: none"> <li>• Screen faceshield over spectacles or goggles</li> <li>• Reflective faceshield over spectacles or goggles</li> </ul>   |  |   |
| <b>CHEMICAL – Liquids, acid and chemical handling, degreasing, plating.</b> |  |  |   |
| <b>Splash, droplets and sprays</b>  | <ul style="list-style-type: none"> <li>• Goggles with indirect ventilation (eyecup or cover type)</li> <li>• Faceshield worn over goggles</li> <li>• Loose-fitting respirator worn over spectacles or goggles</li> <li>• Full-facepiece respirator</li> </ul>  | <p>Atmospheric conditions and the restricted ventilation of a protector can cause lenses to fog. Frequent cleaning may be required.</p> <p>To provide adequate protection, ensure goggles fit tightly to the face.</p>   | Splash/droplet: <b>D3</b>   |
| <b>Irritating Mist</b>  | <ul style="list-style-type: none"> <li>• Goggle with no ventilation (cover type)</li> <li>• Faceshield worn over goggles</li> <li>• Loose-fitting respirator worn over spectacles or goggles</li> <li>• Full-facepiece respirator</li> </ul>   | <p>Atmospheric conditions and the restricted ventilation of a protector can cause lenses to fog. Frequent cleaning may be required.</p> <p>To provide adequate protection, ensure goggles fit tightly to the face.</p>   | NOTE: There are currently no marking designations for eye protection to Irritating mists exposure in the ANSI/ISEA Z87.1-2020 standard. |
| <b>DUST - Woodworking, buffing, general dusty conditions</b>                |  |  |   |
| <b>Nuisance dust</b>  | <ul style="list-style-type: none"> <li>• Goggles with direct or indirect ventilation (eyecup or cover type)</li> <li>• Full-facepiece respirator</li> </ul>  | <p>Atmospheric conditions and the restricted ventilation of a protector can cause lenses to fog. Frequent cleaning may be required.</p> <p>To provide adequate protection, ensure goggles fit tightly to the face.</p>   | Dust: <b>D4</b>   |
| <b>Fine dust</b>  | <ul style="list-style-type: none"> <li>• Goggles with indirect ventilation or no ventilation</li> <li>• Full-facepiece respirator</li> </ul>   | To provide adequate protection, ensure goggles fit tightly to the face.  | Fine dust: <b>D5</b>  |
| <b>OPTICAL RADIATION</b>  |  |  |   |
| <b>Infrared Radiation (IR)</b>  | <ul style="list-style-type: none"> <li>• Spectacles with side protection</li> <li>• Goggles with direct or indirect ventilation</li> <li>• Faceshield worn over spectacles or goggles</li> <li>• Welding helmet worn over spectacles or goggles</li> <li>• Loose-fitting respirator worn over spectacles or goggles</li> <li>• Full-facepiece respirators</li> </ul> | <p>For proper fit of protector; there shall be no penetration of direct infrared spectra light in all non-lens areas.</p> <p>Side shields shall have filtering capability equal to or greater than the front lenses.</p> | IR: <b>R</b> and scale number   |

| Hazard                            | Protectors   | Limitations   | Marking <sup>1</sup>  |
|-----------------------------------|--|---|---|
| <b>Visible Light (Glare)</b>      | <ul style="list-style-type: none"> <li>• Spectacles with side protection</li> <li>• Goggles with direct or indirect ventilation</li> <li>• Faceshield worn over spectacles or goggles</li> <li>• Welding helmet worn over spectacles or goggles</li> <li>• Loose-fitting respirator worn over spectacles or goggles</li> <li>• Full-facepiece respirators</li> </ul> | <p>For proper fit of protector; there shall be no penetration of direct visible light in all non-lens areas.</p> <p>Sideshields shall have filtering capability equal to or greater than the front lenses.</p>    | Visible: <b>L</b> and <i>scale number</i>   |
| <b>Ultraviolet Radiation (UV)</b> | <ul style="list-style-type: none"> <li>• Spectacles with side protection</li> <li>• Goggles with direct or indirect ventilation</li> <li>• Faceshield worn over spectacles or goggles</li> <li>• Welding helmet worn over spectacles or goggles</li> <li>• Loose-fitting respirator worn over spectacles or goggles</li> <li>• Full-facepiece respirators</li> </ul> | <p>For proper fit of protector; there shall be no penetration of direct ultraviolet light in all non-lens areas</p> <p>Sideshields shall have filtering capability equal to or greater than the front lenses.</p> | UV: <b>U</b> and scale number   |
| <b>Lasers</b>                     | Refer to ANSI Z136.1-2014 "Safe Use of Lasers", for guidance in choosing the correct protective eyewear when working with lasers.  |   | NOTE: There are currently no marking designations for eye protection to Lasers in the ANSI/ISEA Z87.1-2020 standard.          |
| <b>Electric Arcs</b>              | Refer to NFPA 70E-2018 "Standard for Electrical Safety in the Workplace", for guidance in choosing the correct protective eyewear when working on electrical equipment.  | Only faceshields provide compliant eye and face protection, worn over protective spectacles.  | NOTE: There are currently no marking designations for eye protection to electrical arcs in the ANSI/ISEA Z87.1-2020 standard. |

| Hazard   | Protectors   | Limitations   | Marking <sup>1</sup>  |
|--|--|---|---|
| <p><b>Arc Welding: Arc</b></p> <p>Process Examples:<br/>Shielded Metal Arc Welding (SMAW)</p> <p>Gas Metal Arc Welding (GMAW)</p> <p>Gas Tungsten Arc Welding (GTAW)</p> <p>Air Carbon Arc Welding (CAC-A)</p> <p>Carbon Arc Welding (CAW)</p> <p>Plasma Arc Welding (PAW)</p> <p>Plasma Arc Cutting (PAC)</p> <p>Viewing electric arc furnaces and boilers.</p> | <ul style="list-style-type: none"> <li>• Welding helmet over spectacles or goggles</li> <li>• Handshield over spectacles or goggles</li> <li>• Welding Respirator</li> <li>• TYPICAL FILTER LENS SHADE: 10-14</li> </ul> | <p>Protection from optical radiation is directly related to filter lens density. Select the darkest shade that allows adequate task performance.</p> <p>For proper fit of protector; there shall be no penetration of direct visible light in all non-lens areas.</p> <p>Sideshields shall have filtering capability equal to or greater than the front lenses. Welding helmets are intended to shield the eyes and face from optical radiation, heat, and impact. Welding helmets should not be used as stand-alone protective devices and should be worn in conjunction with goggles or spectacles.</p> <p>Filter lens shade selection is to be made based on the welding process, arc current, electrode size and/or plate thickness. Use ANSI Z49.1:2012, Table 1, Guide for Shade Numbers, to select the proper filter lens shade for both protection and comfort (reduction in visible glare).</p> <p><b>Note:</b> Filter lenses shall meet the requirements for shade designations in table 7 of ANSI/ISEA Z87.1-2020.</p> | <p>Welding: <b>W</b> shade number</p> <p>UV: <b>U</b> scale number</p> <p>Visible: <b>L</b> scale number</p> <p>IR: <b>R</b> scale number</p> <p>Variable tint: <b>V</b></p> <p>Special purpose: <b>S</b></p> |

| Hazard  | Protectors   | Limitations  | Marking <sup>1</sup>  |
|---|--|--|---|
| <p><b>Oxyfuel Gas Welding:</b></p> <p>Process Examples:<br/>Oxyfuel Gas Welding (OFW)</p> <p>Viewing gas-fired furnaces and boilers</p> | <ul style="list-style-type: none"> <li>• Welding goggles</li> <li>• Welding helmet over spectacles or goggles</li> <li>• Welding faceshield over spectacles or goggles</li> </ul> <p>TYPICAL FILTER LENS SHADE: 6 -8</p> | <p>Protection from optical radiation is directly related to filter lens density. Select the darkest shade that allows adequate task performance.</p> <p>For proper fit of protector; there shall be no penetration of direct visible light in all non-lens areas.</p> <p>Sideshields shall have filtering capability equal to or greater than the front lenses.</p> <p>Welding helmets are intended to shield the eyes and face from optical radiation, heat, and impact. Welding helmets should not be used as stand-alone protective devices and should be worn in conjunction with goggles or spectacles</p> <p>Filter lens shade selection is to be made based on the welding process, arc current, electrode size and/or plate thickness. Use ANSI Z49.1:2012, Table 1, Guide for Shade Numbers, to select the proper filter lens shade for both protection and comfort (reduction in visible glare).</p> | <p>Welding: <b>W</b> shade number</p> <p>UV: <b>U</b> scale number</p> <p>Visible: <b>L</b> scale number</p> <p>IR: <b>R</b> scale number</p> <p>Variable tint: <b>V</b></p> <p>Special purpose: <b>S</b></p> |
| <p><b>Oxyfuel or Oxygen Cutting</b></p>   | <ul style="list-style-type: none"> <li>• Welding goggles</li> <li>• Welding helmet over spectacles or goggles</li> <li>• Welding faceshield over spectacles or goggles</li> </ul> <p>TYPICAL FILTER LENS SHADE:3-6</p>   | <p><b>Note:</b> Filter lenses shall meet the requirements for shade designations in table 7 of ANSI/ISEA Z87.1-2020.</p>   |   |
| <p><b>Torch brazing</b></p>   | <ul style="list-style-type: none"> <li>• Welding goggles</li> <li>• Welding helmet over spectacles or goggles</li> <li>• Welding faceshield over spectacles or goggles</li> </ul> <p>TYPICAL FILTER LENS SHADE: 3-4</p>  |  |   |
| <p><b>Torch soldering</b></p>   | <ul style="list-style-type: none"> <li>• Spectacles</li> <li>• Welding faceshield over spectacles</li> </ul> <p>TYPICAL FILTER LENS SHADE: 2</p>   | <p>Shade or special purpose lenses, as suitable.</p> <p><b>Note:</b> Refer to definition of special purpose lenses in ANSI/ISEA Z87.1-2020.</p>  |   |
| <p><b>Glare</b></p>   | <ul style="list-style-type: none"> <li>• Spectacles with or without side protection</li> <li>• Faceshield over spectacles or goggles.</li> </ul>   |  |   |

1. Refer to ANSI/ISEA Z87.1-2020 Table 3 for complete marking requirements.

2. Refer to ANSI Z49.1: 2012: "Safety in Welding, Cutting, and Allied Processes", Table 1, Guide for Shade Numbers, to select the proper lens filter protective shade based on welding process, arc current (in amperes), Electrode Size (arc welding only) and metal plate thickness (for oxyfuel and oxygen cutting only).

3. Refer to ANSI Z136.1-2014 "Safe Use of Lasers", for guidance on choosing the correct protective eyewear when working with lasers.

## **Annex K. Hazard Assessment and Protector Selection** (informative)

### **K.1 General**

Protectors should be required where there is a reasonable probability of an eye or face injury that could be minimized or prevented by the use of such protection. In such cases, employers and educational authorities should make eye and face protectors conveniently available to employees and students for their use in the work environment, per applicable federal and state regulations. The employees and students should use such protectors. Where there is a reasonable probability of impact from flying objects, a protector with side protection should be required.

Known hazards should be removed or minimized to the extent possible. Protectors are not substitutes for engineering controls and sound safety practices. Protectors alone should not be relied upon to provide the sole means of protection against eye and face hazards. Protectors should be used in conjunction with engineering controls and sound safety practices.

Employers and employees should consult their federal, state and local safety and health regulatory authorities to become knowledgeable of the legal requirements applicable to their area. Under the Department of Labor, the Federal Occupational Safety and Health Administration (Fed OSHA) has codified in 29 Code of Federal Regulations (CFR) 1910 *Occupational Safety and Health Standards* and 29 CFR 1926 *Safety and Health Regulations for Construction* specific legal requirements and guidelines that employers must follow to protect their employees adequately (see specifically 29 CFR 1910.133 and 29 CFR 1926.102). By law, state and local government authorities can implement their own safety and health regulations if they are at least as protective as the federal regulations.

### **K.2 Hazard Assessment**

The safety officer or other knowledgeable, responsible party should conduct an eye and face hazard assessment of the occupational or educational work setting. The hazard assessment should determine the risk of exposure to eye and face hazards, including those which may be encountered in an emergency. Employers should be aware of the possibility of multiple and simultaneous hazard exposures and be prepared to protect against the highest level of each hazard. Eye and face protectors alone should not be relied on to provide protection against any identified hazards, but should be used in conjunction with guards, engineering controls, and sound occupational and educational safety practices. At the minimum, the following hazard assessment procedure should be conducted to identify the existing and anticipated hazards and select appropriate eye and face protectors:

**(1) Survey the Work Area.** Conduct a walk-through survey of the area. The purpose of the survey is to identify sources of potential eye and face hazards. Consideration should be given to the six hazard categories addressed by this standard:

- Impact
- Heat
- Liquid Splash
- Dust
- Glare
- Optical Radiation

**(2) Identify Sources of Hazards.** During the walk-through observe the following:

- Sources of motion; i.e., machinery or processes where any movement of tools, machine

elements or particles could exist, or movement of personnel that could result in collision with stationary objects.

- Sources of high temperatures that could result in facial burns, eye injury or ignition of protective equipment, etc.
- Types of chemical exposures.
- Sources of particles (i.e., dust, sparks, spray, mist).
- Sources of optical radiation, i.e., welding, brazing, cutting, furnaces, heat treating, high intensity light sources and ultraviolet lamps.
- Layout of workplace and location of other personnel.
- Any electrical hazards.

**(3) Organize Data.** Following the walk-through survey, organize the data and information for use in the assessment of hazards. The objective is to prepare for an analysis of the hazards in the environment to enable proper selection of protective equipment.

**(4) Analyze Data.** Having gathered and organized data on a workplace, make an estimate of the potential for eye and face injury. Each of the basic hazards should be reviewed and a determination made as to the type and level of each of the hazards found in the area. The possibility of exposure to several hazards simultaneously should be considered.

**(5) Selection.** Specify the protector(s) suitable for the hazards identified (see Annex J, Eye and Face Selection Guide).

**(6) Reassessment of Hazards.** A periodic reassessment of the work area should be performed on a regular basis to identify changes in the hazard situation that could affect the level of protection required. Reassess the workplace hazard situation by identifying and evaluating new equipment and processes, reviewing incident records, and reassessing the suitability of previously selected eye and face protection.

### K.3 Protector Selection

After completing a thorough hazard assessment of the environment such as recommended in Annex K.2, the general procedure for selection of protective equipment is as follows:

- (1) Become familiar with the Eye and Face Protector Selection Guide (Annex J), the types of protective equipment that are available, their capabilities and limitations.
- (2) Compare the hazards associated with the environment, i.e., impact velocities, masses, projectile shape, radiation intensities, etc., with the available protective equipment.
- (3) Make a judgment in selection of the appropriate protective equipment so that the protection is consistent with the reasonably probable hazard.
- (4) Protectors not specifically rated for impact or protectors complying only with the applicable requirements of Section 5 may be used only in an environment where the known or presumed impact, radiation and dust, mist and splash hazards do not exist or are of minimal intensity or probability of occurrence. Impact-rated protectors should be used in an environment when the known or presumed hazards are of a high velocity, high mass or high impact nature.
- (5) Provide and fit the user with the protector and provide instruction on its care, use and limitations as recommended in Annexes K.4 and K.6.

(Note: Be aware that spectacles, goggles, and face shields are tested with different impact criteria so the protector selection should be consistent to the testing.)

The selection guide is intended to aid in identifying and selecting the types of eye and face protectors that are available. The capabilities and limitations for the hazard are listed in this guide. This guide is not intended to be the sole reference in selecting the proper eye and face protector.

#### **K.4 Product Use and Limitations**

Protectors are a personal item. They should be issued for exclusive use by a particular individual. However, in circumstances where protectors are reissued, the protectors should be maintained in a sanitary and reliable condition.

Caution should be exercised to ensure that the level of protection provided by any protector is adequate for its intended purpose.

See the Selection Chart for information on specific applications.

Additional information regarding training can be found in the ANSI/ASSP Z490.1-2016, *Criteria for Accepted Practices in Safety, Health, and Environmental Training*.

#### **K.5 Special Purpose Protectors and Lenses**

Special purpose protectors and lenses are those which meet the requirements of Table 11, but do not meet the requirements of, Table 7, Table 8, Table 9 or Table 10. They are designed for specific applications. They might not provide adequate ultraviolet protection, infrared protection, or ultraviolet and infrared protection when used for applications for which they are not designed. Therefore, special purpose protectors and lenses should be used only after a complete hazard assessment and at the discretion of the individual responsible for the selection of protectors.

#### **K.6 Prescription (Rx) Eyewear**

Wearers of prescription (Rx) eyewear should wear eye protection that incorporates the prescription in its design or that can be worn over prescription lenses without disrupting either the prescription eyewear or the protective eyewear.

Contact lens wearers should recognize that dusty and/or chemical environments may represent an additional hazard. Contact lenses are not protectors. If contact lens wear is authorized and medically approved for the use in a hazardous environment, they should only be worn in conjunction with appropriate eye protectors.

#### **K.7 Filter Lenses and Windows**

A filter lens meets the ultraviolet, luminous and infrared transmittance requirements of Table 7, Table 8, Table 9, or Table 10 and is permanently marked with a shade/scale number that indicates its transmittance levels in accordance with Table 8, Table 9 or Table 10. Filter lenses of an appropriate shade are suitable for protection from direct exposure to optical radiation from sources of very high radiance, such as welding arcs. Filter lenses are also suitable for protection from sources of low radiance, provided they are not so dark as to interfere with normal visual performance of the task.

## **K.8 Tinted Lenses and Windows**

Lenses having low luminous transmittance should not be worn indoors, except when needed for protection from optical radiation. Care should be exercised in conjunction with wearing such lenses for driving vehicles with tinted windshields or for night driving. Some polarized lenses may present viewing problems when reading liquid crystal displays. Some tinted lenses may absorb certain wavelengths of visual displays or signs, rendering them unreadable.

As an example, amber colored sunlenses (“blue-blockers”) may greatly weaken the intensity of a blue light indicating the presence of overhead power lines.

Safety personnel should “field-test” tinted lenses with workers before authorizing tinted lenses for on-the-job wear.

## **K.9 Photochromic Lenses**

Photochromic lenses darken when exposed to, and fade when removed from, ultraviolet radiation or sunlight. They are frequently used to provide comfortable vision for a wide range of ambient illumination. They should be used with care where the wearer passes from outdoors to indoors in the course of the job. Photochromic lenses that do not meet the transmittance requirements of Table 7 and the switching index requirements of Table 12 are not suitable for protection from direct exposure to high radiance sources (e.g., welding arcs and unshielded high intensity lamps). Photochromic lenses that do not meet the switching index requirements in Table 12 are not automatic darkening welding filters. Photochromic lenses should be used only after a complete hazard assessment and at the discretion of the person responsible for the selection of protectors.

## **K.10 Protection from Low Radiance Sources of Ultraviolet and Visible Radiation**

Some lenses that comply with the transmittance requirements of Table 8, but not with all of the requirements of Table 7, can provide sufficient ultraviolet attenuation to be used for protection from direct exposure to ultraviolet sources of low radiance and from indirect exposure (i.e., scattered radiation) to properly shielded ultraviolet sources of high radiance. Lenses that have some attenuation of visible light may also be suitable for protection from scattered light from properly shielded high radiance sources of visible light.

## **K.11 Fitting the Protector**

Careful consideration should be given to comfort and fit. Protectors that fit poorly will not afford the protection for which they were designed. Protectors should be fitted by qualified personnel. Continued wearing of protectors is more likely when they fit the wearer comfortably. Protectors are generally available in a variety of styles and sizes and care should be taken to ensure that the right size is selected for a particular person. For protectors with adjustable fitting features, adjustments should be made on a regular and individual basis for a comfortable fit, which will maintain the protector in its proper wearing position.

Some protectors may not be compatible with other personal protective equipment when worn together, such as goggles with faceshields, goggles with respirators and spectacles with goggles. The end user should carefully match protectors with other personal protective equipment to provide the protection intended.

Because of individual facial characteristics, care must be exercised in fitting goggles to ensure that a tight fit around the face is achieved in order to provide adequate protection.



## **K.12 Goggle Ventilation**

Goggles are commonly available with rigid or flexible frames and are usually ventilated to minimize fogging. Three different types of ventilation are available: Direct ventilated goggles permit the direct passage of air from the work environment into the goggle and are not recommended for use in protection against dust, fine dust or liquid splash hazards. Indirect ventilated goggles permit the passage of air and may prevent the direct passage of liquids and/or optical radiation. Goggles with no provision for ventilation minimize passage of dusts, mist, liquid splash and vapor.

## **K.13 Peripheral Vision**

Some job functions may require special attention to an individual's ability to perceive objects and/or potential hazards located in the periphery of their visual field (commonly referred to as peripheral vision) while wearing eye and face protection. These may include, but are not limited to; steel workers, ship builders, construction workers and powered equipment operators such as forklift operators, truck drivers and railroad workers. A proper hazard assessment should be performed to determine whether peripheral vision is a significant factor in the safety of the workplace and/or individual.

Assessing peripheral vision typically involves determining the "field of view", which is usually measured horizontally from an individual's nasal bridge outward. Field of view may also include a vertical measurement. There are a variety of methods for measuring field of view, and the appropriate one may depend on the workplace hazard assessment and/or job function. Due to the wide range of designs among protectors and individual fit, the ability of a particular eye and face protection product to provide an adequate field of view may be best determined by trying different types and/or styles on the individual.

## **K.14 Optical Levels**

Certain job tasks and applications may be performed when wearing eye protection that has relaxed optics requirements for refractive power, astigmatism, and resolving power for lenses and replacement lenses. These may include but are not limited to first responders or military personnel engaged in tasks such as general on-site logistics, victim extraction, general fire-fighting activities not requiring self-contained breathing apparatus, facility tear down, and tactical situations. Such relaxed optics may not be suitable for machinery operation, laboratory environments, or precision work and therefore should be evaluated based upon the end use and hazards involved.

The selection of a protector's optical level for a given use should be conducted in accordance with this Annex K. Hazard Assessment and Protector Selection.

**Annex L. Examples of Protector Markings**  
(informative)

The information below is provided to demonstrate examples of acceptable and not acceptable product markings compliant with ANSI/ISEA Z87.1-2020. Such information is not meant to be all-inclusive and is provided for illustrative purposes only.

| <b>ACCEPTABLE MARKING EXAMPLES</b>   |                                    |                      |                 |                    |                    |                                     |  |
|--|------------------------------------|----------------------|-----------------|--------------------|--------------------|-------------------------------------|--|
| <b>Device</b>  | <b>Manufacturer's Mark or Logo</b> | <b>Standard Mark</b> | <b>Coverage</b> | <b>Impact Mark</b> | <b>Lens Type</b>   | <b>Use</b>                          | <b>Resulting Mark</b>  |
| <b>Lenses</b>  |                                    |                      |                 |                    |                    |                                     |  |
| Faceshield, impact rated (shade 5)   | <i>Logo</i>                        | <b>Z87</b>           |                 | +                  | <b>W5</b>          |                                     | <i>Logo</i> <b>Z87+W5</b>  |
| Goggle or faceshield, not impact rated (UV)  | <i>Logo</i>                        | <b>Z87</b>           |                 |                    | <b>U6</b>          |                                     | <i>Logo</i><br><b>Z87</b><br><b>U6</b>                             |
| Spectacle, impact rated, special purpose filter                                    | <i>Logo</i>                        |                      |                 | +                  | <b>S</b>           |                                     | <i>Logo</i> + <b>S</b>   |
| <b>Frame</b>   |                                    |                      |                 |                    |                    |                                     |  |
| Goggle, impact rated, fine dust rated  | <i>Logo</i>                        | <b>Z87</b>           |                 | +                  |                    | <b>D5</b>                           | <i>Logo</i> <b>Z87+D5</b>  |
| Goggle, not impact rated, splash rated   | <i>Logo</i>                        | <b>Z87</b>           |                 |                    |                    | <b>D3</b>                           | <i>Logo</i><br><b>Z87D3</b>  |
| Prescription spectacle w/no side protection, tested on smaller head-form           | <i>Logo</i>                        | <b>Z87-2</b>         |                 |                    |                    |                                     | <i>Logo</i> (on one temple)<br><b>Z87-2 H</b><br>(opposite temple) |
| <b>Complete Device</b>   |                                    |                      |                 |                    |                    |                                     |  |
| Goggle or faceshield, impact rated, (UV & IR filters)                              | <i>Logo</i>                        | <b>Z87</b>           |                 | +                  | <b>U6 &amp; R2</b> |                                     | <i>Logo</i><br><b>Z87+</b><br><b>U6</b><br><b>R2</b>               |
| Full facepiece respirator, impact rated, splash rated, dust rated, fine dust rated | <i>Logo</i>                        | <b>Z87</b>           |                 | +                  |                    | <b>D3</b><br><b>D4</b><br><b>D5</b> | <i>Logo</i><br><b>Z87+</b><br><b>D3D4D5</b>                        |

| UNACCEPTABLE MARKING EXAMPLES   |                             |               |          |             |                  |                  |  |
|---|-----------------------------|---------------|----------|-------------|------------------|------------------|--|
| Device  | Manufacturer's Mark or Logo | Standard Mark | Coverage | Impact Mark | Lens Type        | Use              | Incorrect Resulting Mark   |
| <b>Lenses</b>   |                             |               |          |             |                  |                  |  |
| Goggle or faceshield, impact rated, (UV & IR)                                       | <i>Logo</i>                 | <b>Z87</b>    |          | +           | <b>U3<br/>R3</b> |                  | <b>Logo (on side)<br/>Z87+UV3 IR3<br/>(on opposite side)</b><br><br>Reason: Incorrect markings for ultraviolet (U) and infrared (R) designations |
| <b>Frame</b>  |                             |               |          |             |                  |                  |  |
| Goggle, not impact rated, splash and dust rated                                     | <i>Logo</i>                 | <b>Z87</b>    |          |             |                  | <b>D3<br/>D4</b> | <b>Logo Z87(on top of housing)<br/>D3 D4 (on side of housing)</b><br><br>Reason: Z87 designation and use markings not in reasonable proximity.   |
| <b>Complete Device</b>  |                             |               |          |             |                  |                  |  |
| Faceshield, impact rated, special purpose electric arc, certified for use in Canada | <i>Logo</i>                 | <b>Z87</b>    |          | +           | <b>S</b>         |                  | <b>Logo<br/>NFPA arc rating<br/>Z94.3/Z87+S</b><br><br>Reason: Includes intermixed markings from other standards.                                |